

# BAR PULLERS FOR CNC LATHES

## SBM BAR PULLERS

Coolant or Air Actuated  
2, 3 & 4 Finger Models

An Inexpensive And Simple Way To Automate Your CNC Lathe- Automatically Pulls And Precisely Positions Bar Stock Through The Chuck, Eliminating Manual Loading And Unloading Of Each And Every Part!



**No Down Time**-machine continues to run, freeing operator to work other jobs.  
**Self Adjusting & Self Releasing**-After initial setting, no adjustment required for different sizes, and needs only 1/4" of bar length to pull bar!  
**2, 3 & 4 Finger Design**-Holds round and square parts. Can also hold hex and flat parts with 2 fingers.  
**Pull Threaded or Delicate Material**-Simply use the optional soft steel, aluminum, brass or delrin fingers.  
**Bar Can Be Pulled and Positioned Multiple Times** for machining various sections of the part before cutoff.  
**Great for Sub-Spindle Lathes**- use as a "pick and place" device for finished parts.  
**Quick Installation**- comes complete with fingers and bar support collar...be "up and running" within 1 hour!

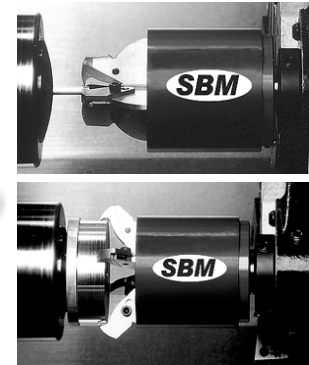
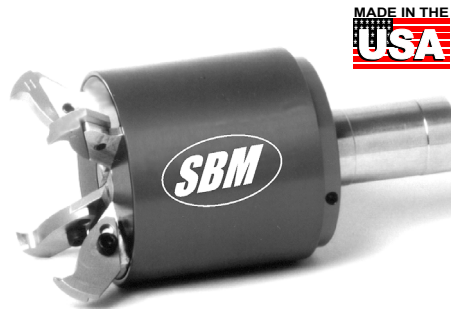

**Increase your PROFITS by \$50,000-\$100,000 per year!**

**RISK FREE GUARANTEE!**  
Use the SBM Bar Puller for 30 Days, and if you are not Completely Satisfied, you can return it for your money back... No Questions Asked!



Shank Type	# of Fingers	Part Number	Price
<b>MINI BAR PULLER-1/8" to 1-1/8" Capacity</b>			
5/8" Round	4	BU-MGA010	\$359.00
16mm Round	4	BU-MGAR16MM	\$489.00
<b>LARGE BAR PULLER-1/8" to 3-1/8" Capacity</b>			
1" Round Shank	2	BU-GA1000-2	\$475.00
	3	BU-GA1000-3F	\$395.00
	4	BU-GA1000	\$395.00
VDI 30	4	BU-GA1000VDI-30	\$599.00
VDI 40	4	BU-GA1000VDI-40	\$599.00

## CLEARANCE DIMENSIONS

Size	Gripping Range	A	B	C	D	E	F
Large Puller	1/8" to 2 -1/2" 1st setting	3 5/8"	2 1/2"	2 7/8"	Shank	1 3/4"	2 3/4"
	3/4" to 3- 1/8" 2nd setting	4"	3 1/8"	2 7/8"	Shank	1 3/4"	2 3/4"
Mini Puller	1/8" to 1 1/8"	1 5/8"	1 1/8"	1 7/8"	Shank	1 3/4"	1 5/8"

SBM Bar Pullers are shipped complete with 1 set of hard steel fingers and 1 bar support collar. (Mini Puller comes with 1.25" collar, Large Puller comes with 3" collar)

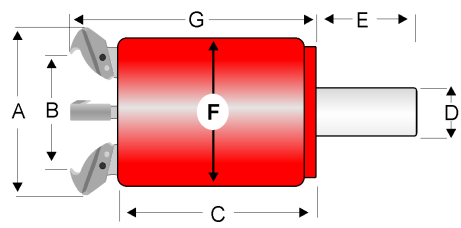

## BAR PULLER ACCESSORIES

Save Time-Stock Up on Additional Collars!

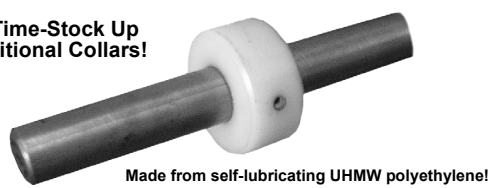

### Bar Support Collars

Width	OD	Part Number	Price
3/4"	1 1/4"	BU-COLLAR-1.25	\$11.50
	2 1/2"	BU-COLLAR-2.50	\$13.00
	3"	BU-COLLAR-3.00	\$14.00

Replacement Fingers are 100% compatible with "Omni" bar pullers!

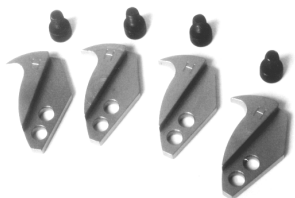

### Replacement Fingers (Set of 4)

Finger Type	Large Puller	Mini Puller	Price
Hard Steel	BU-GAFHS4	BU-MGAFHS4	\$69.00
Soft Steel	BU-GAFSS4	BU-MGAFSS4	\$69.00
Aluminum	BU-GAFAL4	BU-MGAFAL4	\$69.00
Brass	BU-GAFBR4	BU-MGAFBR4	\$69.00
Delrin	BU-GAFDL4	BU-MGAFDL4	\$69.00

## INSTALLATION



1. Place bar support collar around barstock. Tighten set screw.
2. Place barstock in drawtube.
3. Place SBM Bar Puller in tool station.
4. Coolant or Air externally or internally actuated.
5. Program machine.

**NOTE:** It is important that under no circumstances should any length of bar be left sticking outside the drawtube. This can result in damage to the machine and injury to the operator.

Call Us Today For All Of Your Machine Tool Needs!

## Automate Any CNC Lathe!

Bar pullers provide a simple, inexpensive method for automating any CNC lathe. Bar Pullers cost much less than a bar feed and do not use up valuable floor space. Providing a maintenance-free operation, bar pullers are very easy to set up and use- no electrical interface is required. A wide gripping range is obtained from a compact design and they can be easily moved from one machine to another.

## CNC COMPACT BAR PULLER

Extremely compact - Designed for small CNC machines where tool interference is a problem.

### FEATURES:

- Eliminates the need for expensive bar feeds.
- Gripping range from 1/8" - 4"
- Flexible heat-treated steel fingers provide strong gripping force.
- Also available in VDI shank styles.
- Standard jaws have a serrated gripping surface for increased holding power (smooth jaws available).
- Unit easily handles round, square, and hex stock.
- Finger holders and racks are serrated to provide positive location.
- All wear subjected parts are hardened for strength and long life.
- Comes with one set of standard jaws and one blank spindle bushing.

Easy Set-Up!

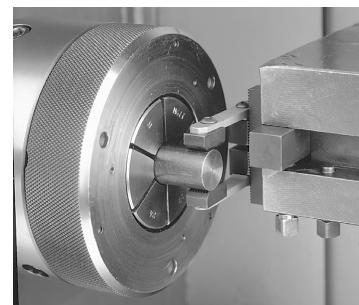
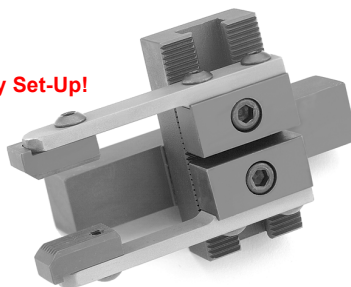

**Full Line Available!**  
Please call for more information.

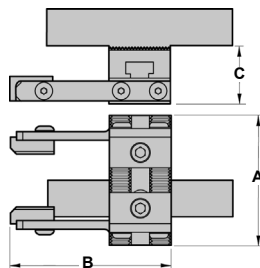

Shank Size	Gripping Range	A	B	C	Part Number	Price Each
1/2" SQ	1/8" - 1 5/8"	2 1/8	3 3/4	1 3/16	ROY-43300	\$769.30
3/4" SQ	1/8" - 2 1/4"	2 5/8	3 3/4	1 3/16	ROY-43302	\$769.30
1" SQ	1/8" - 2 1/4"	2 5/8	3 3/4	1 3/16	ROY-43304	\$769.30
1" SQ	1/8" - 3"	3 5/8	3 3/4	1 3/16	ROY-43306	\$819.28

### Compact Model Replacement Parts

Description	Part Number	Price Per Set
Spring Fingers	ROY-43505	\$96.04
Serrated Jaws	ROY-43500	\$138.18
Smooth Jaws	ROY-43502	\$168.56

## CNC HEAVY DUTY BAR PULLER

- Gripping range from 1/8" to 6-1/2"
- Gripping force is easily adjusted by altering spring pressure.
- Available in square, round, and VDI shank styles.
- Jaws have two gripping surfaces:  
Serrated for increased gripping power.  
Smooth to help prevent marking.
- Unit easily handles round, square, and hex stock.
- Jaws and racks are serrated to provide positive location.
- All wear subjected parts are hardened for strength and long life.
- Eliminates the need for expensive bar feeds.
- Comes with one set of standard jaws and one blank spindle bushing.

Round Shank

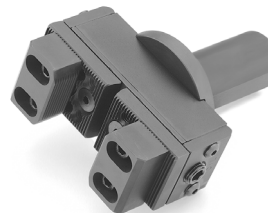
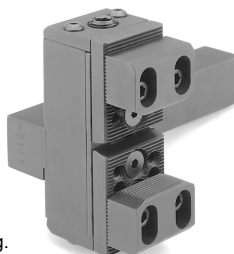

Square Shank

Square Shank

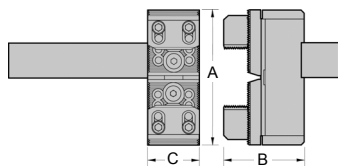

### Gripping Range

Square Shank	Standard Jaws	Extra Cap. Jaws	A	B	C	Right Hand Part Number	Price Each
3/4" SQ	1/8" - 2-1/4"	1-7/8" - 3-3/4"	3-7/8"	2- 9/16"	1-1/2"	ROY-43360	\$1,151.50
1" SQ	1/8" - 2-1/4"	1-7/8" - 3-3/4"	3-7/8"	2- 9/16"	1-1/2"	ROY-43366	\$1,224.02
1" SQ	1/8" - 3-1/2"	1-7/8" - 5-3/8"	4-3/4"	2- 9/16"	1-1/2"	ROY-43370	\$1,277.92
1" SQ	1/8" - 3-5/8"	1-7/8" - 5-1/2"	5"	2-3/4"	1-3/4"	ROY-43372	\$1,318.10
1" SQ	1/8" - 4-7/8"	1-7/8" - 6-1/2"	6-3/4"	2-3/4"	1-3/4"	ROY-43376	\$1,474.90

Round Shank

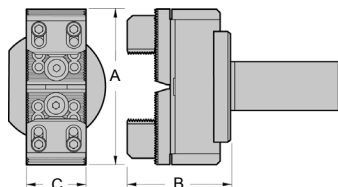

### Gripping Range

Round Shank	Standard Jaws	Extra Cap. Jaws	A	B	C	Part Number	Price Each
1" dia.	1/8" - 2-1/4"	1-7/8" - 3-3/4"	3-7/8"	2 -5/16"	1-1/2"	ROY-43400	\$1,461.18
1-1/4" dia	1/8" - 2-1/4"	1-7/8" - 3-3/4"	3-7/8"	2 -5/16"	1-1/2"	ROY-43402	\$1,461.18
1-1/4" dia	1/8" - 3-1/2"	1-7/8" - 5-3/8"	5-3/8"	2 -5/16"	1-1/2"	ROY-43404	\$1,526.84

## REPLACEMENT JAWS

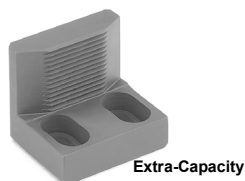
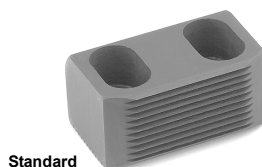

Description	Part Number	Price Per Set
Standard	ROY-43510	\$189.14
Extra-Capacity	ROY-43512	\$219.52

Call Us Or Visit Our Website For Our Complete Selection!

# BAR PULLERS FOR CNC LATHES

## GRIPPEX COOLANT ACTUATED BAR PULLERS

### Model 20L

The patented Grippex 20L CNC Bar Puller is actuated by a CNC lathe's coolant system. As coolant is fed through the unit, it pushes a piston forward which causes the fingers to close down on the bar stock. When the coolant is turned off, the fingers automatically spring open. With this bar puller, no adjustment by the operator is necessary - the fingers simply close down until they contact the bar. This feature is especially useful for making multiple pulls on the same workpiece, even after the OD has been turned.

The Grippex Coolant Actuated Bar Puller is also useful as a part loader/unloader. When fitted with special jaws, this tool can:

- Remove finished parts from a machine's subspindle and place them into the parts catcher, eliminating the need for unreliable ejectors and enables the subspindle to swallow longer parts.
- Remove a bar remnant and drop it in the parts catcher for disposal, preventing the remnant from falling into the chip conveyor where it could become jammed and cause damage to the conveyor.

The Grippex Bar Puller achieves very high gripping force through a patented finger mechanism that pivots on roller bearings. As little as 15 psi of coolant pressure is enough to enable the Grippex to pull a 210 lb. bar! Unit can also be operated by air pressure for custom applications.



**Can Be Operated By Coolant Or Compressed Air-Only 15 PSI is enough to pull a 210 lb bar!**

### Here's How It Works:

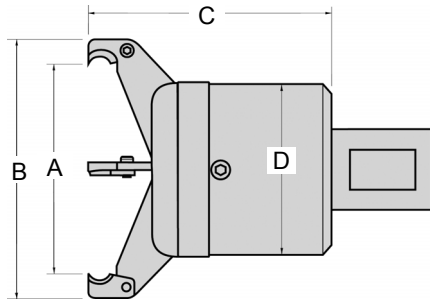
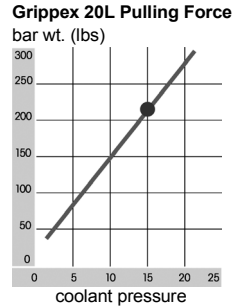
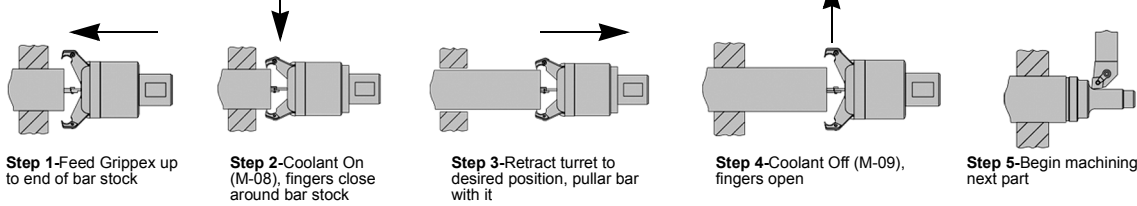

Shank Size	Gripping Range	A	B	C	D	Part Number	Price
1"	1/8" - 2-3/8"	2-3/8	3-1/4	3-1/2	2-11/16	ROY-43140	\$1,462.16
1-1/4"	1/8" - 3-1/8"	3-1/8	4	3-11/16	2-11/16	ROY-43145	\$1,462.16
1-1/2"	1/8" - 4-1/8"	4-1/8	5-1/16	4-1/4	2-11/16	ROY-43150	\$1,462.16

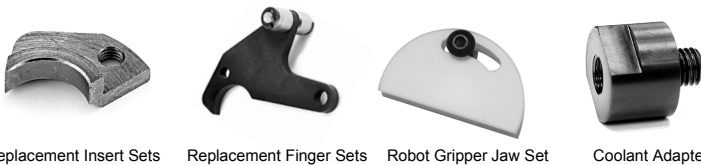

### Grippex Bar Puller Accessories

Description	Capacity	Part Number	Set Price
Replacement Fingers	1/8" - 2-3/8"	ROY-43170	\$162.68
	1/8" - 3-1/8" (std)	ROY-43175	\$177.38
	5/16" - 4-1/8"	ROY-43180	\$332.22
Replacement Inserts		ROY-43185	\$119.56
Coolant Adapter		ROY-43190	\$119.56
Robot Gripper Jaw Set-for removing finished parts from a subspindle or remnants from main spindle		ROY-43106	\$209.72

## COMBINATION CNC BAR PULLER WITH CUT-OFF TOOL

Eliminates the need to index between cut-off and pulling operations because both tools occupy the same turret location.

- Reduced Indexing Time, Set-up Time and Cycle Time
- Compact design - good for small CNC machines where tool interference is a problem.
- Gripping range from 1/8" - 4", and handles round, square and hex stock.
- Flexible heat-treated steel fingers provide strong gripping force.
- Standard jaws have a serrated gripping surface for increased holding power

### Here's How It Works:

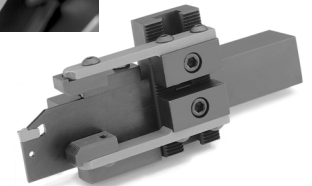
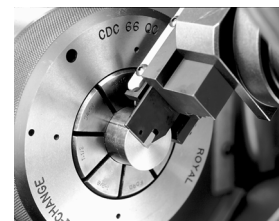
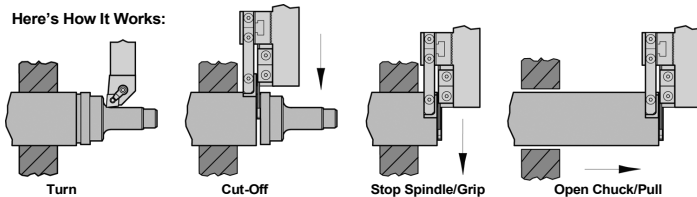

Inserts & holder not included.

### Compatibility Chart

Brand	1/2" or 3/4" Shank	1" Shank
Carboly	150.10-20-3	150.10-25-3
Iscar	SGFH26-3	SGFH32-3
Kennametal	DSB4-340-105	DSB5-340-110
Sandvik	151.2-21-30	151.2-25-30
Valenite	VH101 26 3	VH101 32 3

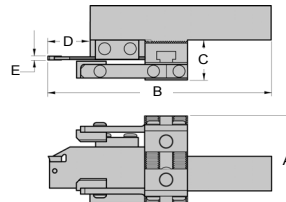

Shank Size	Gripping Range	A	B	C	D1	E	Right Hand Part Number	Price
1/2" SQ	1/8-1 5/8	2 1/8	4 11/16	1-3/16	7/8	0.125	ROY-43452	\$1,000.58
3/4" SQ	1/8-2 1/4	2 5/8	4 3/4	1-3/16	7/8	0.125	ROY-43456	\$1,027.04
1" SQ	1/8-2 1/4	2 5/8	6 3/8	1-3/16	1-1/4	0.125	ROY-43460	\$1,042.72
1" SQ	1/8-3	3 5/8	6 3/8	1-3/16	1-1/4	0.125	ROY-43464	\$1,078.00
1" SQ	1/8-4	3 5/8	6 3/8	1-3/16	1-1/4	0.125	ROY-43468	\$1,225.98

Call Us Today For All Of Your Machine Tool Needs!





## BAR STOCK PULLER FOR CNC LATHES

The lightweight Dunham Bar-Pull, designed for CNC lathes, is self-activating with no moving parts. It does not interfere with other tools or cause turret imbalance, and installs easily in minutes. It uses a shank (available in 7 diameters from 1/2" to 1-1/2") that is clamped in the turret lathe like a boring bar. The grippers are hand turned onto the shank thread or onto adapters that attach to the shank to accept smaller diameter grippers. The grippers are slotted like standard collets and as they advance over the bar, are forced open to firmly grasp the bar for pulling out of the spindle to the programmed length. The gripping and release of the bar is automatic, and the Bar-Pull needs only 1/4" of the bar to engage.

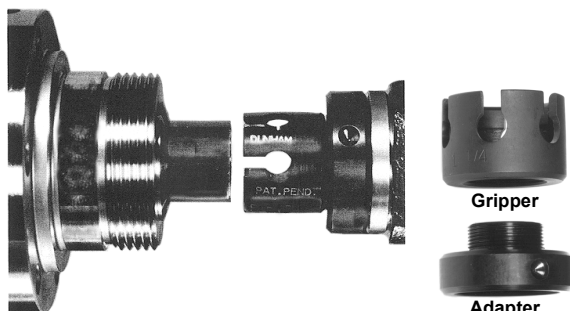

Gripper

Adapter

Shank

### How it works:

- Mount shank in turret, screw on adapter (if required) and gripper.
- Insert bar through back of spindle and clamp with collet or chuck.
- Face off minimum 1/4" projection using parting-off command in CNC program.
- Index turret to Bar-Pull and traverse turret toward spindle for programmed distance, sliding gripper over stock.
- Release clamping pressure on bar.
- Retract turret programmed distance.
- Reclamp bar.
- Retract turret to clear gripper from bar.
- Begin programmed machining cycle.
- Repeat until all bar is used.

### FEATURES:

- Pulls bar to last usable part length
- Pull/positions bar  $\pm 0.001"$
- Eliminates expensive bar feeds
- Works close to chuck or collet nose
- Does not interfere with adjacent tools or turret movement
- Metric grippers also available from 3mm to 34mm! Please call for more information

### ADAPTER

Adaptor Size	Part Number	Price Each
5/8"	DTC-APB0625	\$55.00
1"	DTC-APB1000	

### SHANKS

Shank Size	Part Number	Price Each
1/2"	DTC-PB0500	
5/8"	DTC-PB0625	\$68.00
3/4"	DTC-PB0750	
7/8"	DTC-PB0875	
1"	DTC-PB1000	
1-1/4"	DTC-PB1250	\$68.00
1-1/2"	DTC-PB1500	

### GRIPPERS

Grip Size	Part Number	Price Each
For Use With DTC-APB0625 Adaptor		
3/16"	DTC-PBG0187	
1/4"	DTC-PBG0250	
5/16"	DTC-PBG0312	\$55.00
3/8"	DTC-PBG0375	
7/16"	DTC-PBG0437	
1/2"	DTC-PBG0500	
9/16"	DTC-PBG0562	
5/8"	DTC-PBG0625	\$55.00
11/16"	DTC-PBG0687	
3/4"	DTC-PBG0750	

For Use With DTC-APB1000 Adaptor		
13/16"	DTC-PBG0812	
7/8"	DTC-PBG0875	\$55.00
15/16"	DTC-PBG0937	
1"	DTC-PBG1000	
1-1/8"	DTC-PBG1125	\$55.00
1-1/4"	DTC-PBG1250	

### Direct Mount Grippers

1-5/16"	DTC-PBG1312	
1-3/8"	DTC-PBG1375	
1-7/16"	DTC-PBG1437	\$55.00
1-1/2"	DTC-PBG1500	
1-9/16"	DTC-PBG1562	
1-5/8"	DTC-PBG1625	
1-11/16"	DTC-PBG1687	
1-3/4"	DTC-PBG1750	
1-13/16"	DTC-PBG1812	\$88.00
1-7/8"	DTC-PBG1875	
1-15/16"	DTC-PBG1937	
2"	DTC-PBG2000	

## BAR PULLER KITS

Save time and money by ordering a bar puller kit. Shank must be ordered separately at an additional cost. Kit for gang tool CNC lathes also available please call for more information.



### Bar Puller Kits-(Please Order Shank Separately)

Description	Part Number	Kit Price
11 Grippers (1/4" to 1-1/2" in 1/8" increments) plus 5/8" and 1" adapters.	DTC-BPKIT1	\$443.00
4 Grippers (1 5/8" to 2" in 1/8" increments) plus 1" adapter.	DTC-BPKIT2	\$355.00
6 Grippers (3/16" to 1/2" in 1/16" increments) plus 5/8" adapter.	DTC-BPKIT3	\$218.00
8 Grippers (9/16" to 1" in 1/16" increments) plus 5/8" and 1" adapter.	DTC-BPKIT4	\$348.00
4 Grippers (1 1/8" to 1-1/2" in 1/8" increments) plus 1" adapter.	DTC-BPKIT5	\$260.00
14 Grippers (3/16" to 1" x 1/16" inc.) plus 8 grippers (1-1/8" to 2" x 1/8" inc) plus 5/8" and 1" adapter.	DTC-BPKIT6	\$896.00



## TURRETGANG™ FOR TURRET LATHES

For Gang Style Rapid Tool Change



Wherever You Can Mount  
An OD Toolholder,  
You Can Mount A Turretgang!



- More tools available in your turret
- Immediately reduces manufacturing cycle time
- Mounts in your OD tool holder location on turret
- Right hand design
- Reduces the need for second operations
- Coolant Thru toolholder design

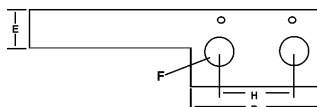

Turret Style	Shank Size E	Head Ext. D	No. Of Tool Loc.	Tool Loc. Size F	Location Spacing H	Part Number	Price Each
Channel	.750	3.50"	3	.750	1.200"	FA-1C35-3CGR	\$324.48
	1.000	2.30"	2	.625	1.200"	FA-1E23-2BGR	\$307.89
	1.000	3.50"	3		1.200"	FA-1E35-3CGR	\$324.48

## 3J& 16C COLLET RACKS

**BEST VALUE**



### FEATURES:

- Protects & organizes your valuable collets
- Sturdy steel construction
- Available for 3J & 16C collets
- 25 holes

Description	Part Number	Price Each
3J Collet Tray	TRAY-125-3J	\$65.00
16C Collet Tray	TRAY-125-16C	\$65.00

Call Us Or Visit Our Website For Our Complete Selection!