

THREAD TURNING INSERTS

PARTIAL PROFILE 60° INSERTS

For Unified (UN-American) and Metric (ISO) Thread Forms

Carmex
Precision Tools Ltd.

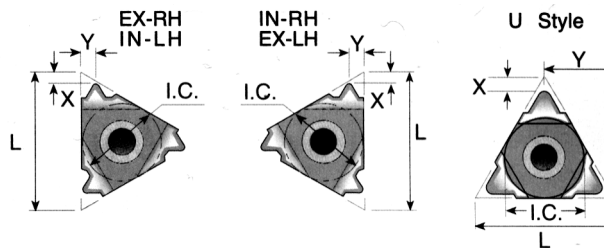
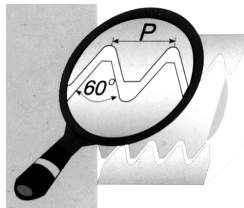

Insert Series	I.C.	Pitch Range				EXTERNAL		INTERNAL		Price Each
		TPI	MM	X	Y	Right Hand Part Number	Left Hand Part Number	Right Hand Part Number	Left Hand Part Number	
6	5/32	48-20	0.5-1.25	.02	.02	-	-	T-C06IRA60__	T-C06ILA60__	\$13.98
8	3/16	48-16	0.5-1.5	.02	.03	-	-	T-C08IRA60__	T-C08ILA60__	\$13.98
8U	3/16U	14-11	1.75-2.0	.03	.16	-	-	T-C08IRLU60__	T-C08IRLU60__	\$13.98
11	1/4	48-16	0.5-1.5	.03	.04	T-C11ERA60__	T-C11ELA60__	T-C11IRA60__	T-C11ILA60__	\$13.98
16	3/8	48-16	0.5-1.5	.03	.04	T-C16ERA60__	T-C16ELA60__	T-C16IRA60__	T-C16ILA60__	\$13.98
	3/8	14-8	1.75-3.0	.05	.07	T-C16ERG60__	T-C16ELG60__	T-C16IRG60__	T-C16ILG60__	\$13.98
	3/8	48-8	0.5-3.0	.05	.07	T-C16ERAG60__	T-C16ELAG60__	T-C16IRAG60__	T-C16ILAG60__	\$13.98
22	1/2	7-5	3.5-5.0	.07	.10	T-C22ERN60__	T-C22ELN60__	T-C22IRN60__	T-C22ILN60__	\$16.45
22U	1/2U	4.5-3.25	5.5-8.0	.02	.43	T-C22UEIRLU60__	T-C22UEIRLU60__	T-C22UEIRLU60__	T-C22UEIRLU60__	\$20.54
27	5/8	4.5-4	5.5-6.0	.08	.12	T-C27ERQ60__	T-C27ELQ60__	T-C27IRQ60__	T-C27ILQ60__	\$26.33
27U	5/8U	4-2.75	6.5-9.0	.04	.54	T-C27UEIRLU60__	T-C27UEIRLU60__	T-C27UEIRLU60__	T-C27UEIRLU60__	\$26.33

Partial Profile 60° - W/ Sintered Chipbreaker

Insert Series	I.C.	TPI	MM	X	Y	Right Hand Part Number	Left Hand Part Number	Right Hand Part Number	Left Hand Part Number	Price Each
16	3/8	48-16	0.5-1.5	.03	.04	T-C16ERBA60__	T-C16ELBA60__	T-C16IRBA60__	T-C16ILBA60__	\$13.98
	3/8	14-8	1.75-3.0	.05	.07	T-C16ERBG60__	T-C16ELBG60__	T-C16IRBG60__	T-C16ILBG60__	\$13.98
	3/8	48-8	0.5-3.0	.05	.07	T-C16ERBAG60__	T-C16ELBAG60__	T-C16IRBAG60__	T-C16ILBAG60__	\$13.98

PARTIAL PROFILE 55° INSERTS

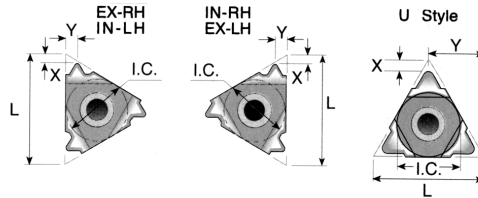
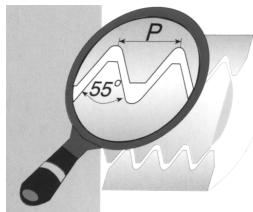

Carmex
Precision Tools Ltd.

Full Line Available!
Please call for more information.

INSERT SERIES	I.C.	Pitch Range				EXTERNAL		INTERNAL		Price Each
		TPI	MM	X	Y	Right Hand Part Number	Left Hand Part Number	Right Hand Part Number	Left Hand Part Number	
6	5/32	48-20	0.5-1.25	.02	.02	-	-	T-C06IRA55__	T-C06ILA55__	\$13.98
8	3/16	48-16	0.5-1.5	.02	.03	-	-	T-C08IRA55__	T-C08ILA55__	\$13.98
8U	3/16U	14-11	1.75-2.0	.04	.16	-	-	T-C08IRLU55__	T-C08IRLU55__	\$13.98
11	1/4	48-16	0.5-1.5	.03	.04	T-C11ERA55__	T-C11ELA55__	T-C11IRA55__	T-C11ILA55__	\$13.98
16	3/8	48-16	0.5-1.5	.03	.04	T-C16ERA55__	T-C16ELA55__	T-C16IRA55__	T-C16ILA55__	\$13.98
	3/8	14-8	1.75-3.0	.05	.07	T-C16ERG55__	T-C16ELG55__	T-C16IRG55__	T-C16ILG55__	\$13.98
	3/8	48-8	0.5-3.0	.05	.07	T-C16ERAG55__	T-C16ELAG55__	T-C16IRAG55__	T-C16ILAG55__	\$13.98
22	1/2	7-5	3.5-5.0	.07	.10	T-C22ERN55__	T-C22ELN55__	T-C22IRN55__	T-C22ILN55__	\$16.45
22U	1/2U	4.5-3.25	5.5-8.0	.04	.43	T-C22UEIRLU55__	T-C22UEIRLU55__	T-C22UEIRLU55__	T-C22UEIRLU55__	\$16.45
27	5/8	4.5-4	5.5-6.0	.08	.11	T-C27ERQ55__	T-C27ELQ55__	T-C27IRQ55__	T-C27ILQ55__	\$26.33
27U	5/8U	4-2.75	6.5-9.0	.05	.54	T-C27UEIRLU55__	T-C27UEIRLU55__	T-C27UEIRLU55__	T-C27UEIRLU55__	\$26.33

Partial Profile 55° W/ Chipbreaker

INSERT SERIES	I.C.	TPI	MM	X	Y	Right Hand Part Number	Left Hand Part Number	Right Hand Part Number	Left Hand Part Number	Price Each
16	3/8	14-8	1.75-3.0	.05	.07	T-C16ERBG55__	T-C16ELBG55__	T-C16IRBG55__	T-C16ILBG55__	\$13.98
	3/8	48-8	0.5-3.0	.05	.07	T-C16ERBAG55__	T-C16ELBAG55__	T-C16IRBAG55__	T-C16ILBAG55__	\$13.98

CARMEX GRADE INFORMATION

Carmex Grade	USST Grade	Carbide ANSI	Coating	Materials
P25C	P5	C5	TIN	Hard Steels
MXC	M2	C2-C3	TIN	Soft Steels, Stainless Steels, Cast Iron
BMA	B4	C3-C4	TIALN	Superalloys, Stainless Steels
K20	K2	C2	UNCOATED	Aluminum, Non Ferrous

How To Order:

- 1) Pick the required insert from table above eg: **T-C11ERA60__**
- 2) Pick a Carbide grade from the Grades table below - eg. B4 for superalloys and stainless steels
- 3) Order Part Number **T-C11ERA60B4**
- 4) Pick toolholder (ext) or boring bar (int) from pages 322-323

Call Us Today For All Of Your Machine Tool Needs!

ISO METRIC FULL PROFILE INSERTS

For Metric Threads, ISO 262, DIN 13

Carmex
Precision Tools Ltd.

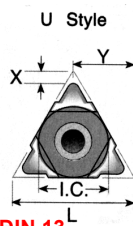
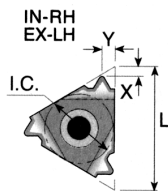
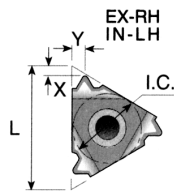
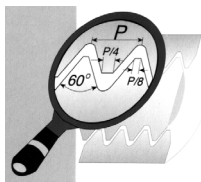

How To Order:

- 1) Pick the required insert from table above eg: **T-C11ERA60__**
- 2) Pick a Carbide grade from the Grades table
B4 for superalloys and stainless steels
- 3) Order Part Number **T-C11ERA60B4**
- 4) Pick toolholder (ext) or boring bar (int) from pages 322-323

ISO METRIC - Full Profile For Metric Threads, ISO 262, DIN 13

INSERT SERIES	I.C.	Pitch MM	EXTERNAL				INTERNAL				Price Each	
			X	Y	Right Hand Part Number	Left Hand Part Number	X	Y	Right Hand Part Number	Left Hand Part Number		
6	5/32	0.5	-	-	-	-	.04	.02	T-C06IR05M__	T-C06IL05M__	\$13.98	
	5/32	0.75	-	-	-	-	.03	.02	T-C06IR075M__	T-C06IL075M__	\$13.98	
	5/32	1.0	-	-	-	-	.03	.02	T-C06IR10M__	T-C06IL10M__	\$13.98	
	5/32	1.25	-	-	-	-	.02	.02	T-C06IR125M__	T-C06IL125M__	\$13.98	
8	3/16	0.5	-	-	-	-	.02	.02	T-C08IR05M__	T-C08IL05M__	\$13.98	
	3/16	0.75	-	-	-	-	.02	.02	T-C08IR075M__	T-C08IL075M__	\$13.98	
	3/16	1.0	-	-	-	-	.02	.02	T-C08IR10M__	T-C08IL10M__	\$13.98	
	3/16	1.25	-	-	-	-	.02	.03	T-C08IR125M__	T-C08IL125M__	\$13.98	
	3/16	1.5	-	-	-	-	.02	.03	T-C08IR15M__	T-C08IL15M__	\$13.98	
	3/16	1.75	-	-	-	-	.02	.03	T-C08IR175M__	T-C08IL175M__	\$13.98	
11	1/4	0.35	.03	.02	T-C11ER035M__	T-C11EL035M__	.03	.01	T-C11IR035M__	T-C11IL035M__	\$13.98	
	1/4	0.4	.03	.02	T-C11ER04M__	T-C11EL04M__	.03	.02	T-C11IR04M__	T-C11IL04M__	\$13.98	
	1/4	0.45	.03	.02	T-C11ER045M__	T-C11EL045M__	.03	.02	T-C11IR045M__	T-C11IL045M__	\$13.98	
	1/4	0.5	.02	.02	T-C11ER05M__	T-C11EL05M__	.02	.02	T-C11IR05M__	T-C11IL05M__	\$13.98	
	1/4	0.6	.02	.02	T-C11ER06M__	T-C11EL06M__	.02	.02	T-C11IR06M__	T-C11IL06M__	\$13.98	
	1/4	0.7	.02	.02	T-C11ER07M__	T-C11EL07M__	.02	.02	T-C11IR07M__	T-C11IL07M__	\$13.98	
	1/4	0.75	.02	.02	T-C11ER075M__	T-C11EL075M__	.02	.02	T-C11IR075M__	T-C11IL075M__	\$13.98	
	1/4	0.8	.02	.02	T-C11ER08M__	T-C11EL08M__	.02	.02	T-C11IR08M__	T-C11IL08M__	\$13.98	
	1/4	1.0	.03	.03	T-C11ER10M__	T-C11EL10M__	.02	.03	T-C11IR10M__	T-C11IL10M__	\$13.98	
	1/4	1.25	.03	.04	T-C11ER125M__	T-C11EL125M__	.03	.03	T-C11IR125M__	T-C11IL125M__	\$13.98	
16	3/8	0.35	.03	.02	T-C16ER035M__	T-C16EL035M__	.03	.01	T-C16IR035M__	T-C16IL035M__	\$13.98	
	3/8	0.4	.03	.02	T-C16ER04M__	T-C16EL04M__	.03	.02	T-C16IR04M__	T-C16IL04M__	\$13.98	
	3/8	0.45	.03	.02	T-C16ER045M__	T-C16EL045M__	.03	.02	T-C16IR045M__	T-C16IL045M__	\$13.98	
	3/8	0.5	.02	.02	T-C16ER05M__	T-C16EL05M__	.02	.02	T-C16IR05M__	T-C16IL05M__	\$13.98	
	3/8	0.6	.02	.02	T-C16ER06M__	T-C16EL06M__	.02	.02	T-C16IR06M__	T-C16IL06M__	\$13.98	
	3/8	0.7	.02	.02	T-C16ER07M__	T-C16EL07M__	.02	.02	T-C16IR07M__	T-C16IL07M__	\$13.98	
	3/8	0.75	.02	.02	T-C16ER075M__	T-C16EL075M__	.02	.02	T-C16IR075M__	T-C16IL075M__	\$13.98	
	3/8	0.8	.02	.02	T-C16ER08M__	T-C16EL08M__	.02	.02	T-C16IR08M__	T-C16IL08M__	\$13.98	
	3/8	1.0	.03	.03	T-C16ER10M__	T-C16EL10M__	.02	.03	T-C16IR10M__	T-C16IL10M__	\$13.98	
	3/8	1.25	.03	.04	T-C16ER125M__	T-C16EL125M__	.03	.03	T-C16IR125M__	T-C16IL125M__	\$13.98	
22	1/2	3.5	.06	.09	T-C22ER35M__	T-C22EL35M__	.06	.09	T-C22IR35M__	T-C22IL35M__	\$16.45	
	1/2	4.0	.06	.09	T-C22ER40M__	T-C22EL40M__	.06	.09	T-C22IR40M__	T-C22IL40M__	\$16.45	
	1/2	4.5	.07	.09	T-C22ER45M__	T-C22EL45M__	.06	.09	T-C22IR45M__	T-C22IL45M__	\$16.45	
	1/2	5.0	.07	.10	T-C22ER50M__	T-C22EL50M__	.06	.09	T-C22IR50M__	T-C22IL50M__	\$16.45	
	22U	1/2U	5.5	.09	.43	T-C22UERL55M__	T-C22UERL55M__	.09	.43	T-C22UIRL55M__	T-C22UIRL55M__	\$16.45
		1/2U	6.0	.10	.43	T-C22UERL60M__	T-C22UERL60M__	.08	.43	T-C22UIRL60M__	T-C22UIRL60M__	\$16.45
	27	5/8	5.5	.07	.11	T-C27ER55M__	T-C27EL55M__	.06	.09	T-C27IR55M__	T-C27IL55M__	\$26.33
		5/8	6.0	.08	.11	T-C27ER60M__	T-C27EL60M__	.07	.10	T-C27IR60M__	T-C27IL60M__	\$26.33
27U	5/8U	8.0	.09	.54	T-C27UERL80M__	T-C27UERL80M__	.09	.54	T-C27UIRL80M__	T-C27UIRL80M__	\$26.33	

ISO METRIC - Full Profile W/SINTERED CHIPBREAKER

16	3/8	0.8	.02	.02	T-C16ERB08M__	T-C16ELB08M__	-	-	-	-	-
	3/8	1.0	.03	.03	T-C16ERB10M__	T-C16ELB10M__	.02	.03	T-C16IRB10M__	T-C16ILB10M__	\$13.98
	3/8	1.25	.03	.04	T-C16ERB125M__	T-C16ELB125M__	.03	.03	T-C16IRB125M__	T-C16ILB125M__	\$13.98
	3/8	1.5	.03	.04	T-C16ERB15M__	T-C16ELB15M__	.03	.04	T-C16IRB15M__	T-C16ILB15M__	\$13.98
	3/8	1.75	.04	.05	T-C16ERB175M__	T-C16ELB175M__	.04	.05	T-C16IRB175M__	T-C16ILB175M__	\$13.98
	3/8	2.0	.04	.05	T-C16ERB20M__	T-C16ELB20M__	.04	.05	T-C16IRB20M__	T-C16ILB20M__	\$13.98
	3/8	2.5	.04	.06	T-C16ERB25M__	T-C16ELB25M__	.04	.06	T-C16IRB25M__	T-C16ILB25M__	\$13.98
	3/8	3.0	.05	.06	T-C16ERB30M__	T-C16ELB30M__	.04	.06	T-C16IRB30M__	T-C16ILB30M__	\$13.98

Call Us Or Visit Our Website For Our Complete Selection!

LATHE CHUCKS
LIVE CENTERS
VISE ACCESSORIES
VISE JAWS
STRAIGHT SHANK COLLET HOLDERS
TAP HOLDERS
DRILL CHUCKS
CARBIDE INSERTS
THREADING/GROOVING
CUTTING TOOLS
MACHINERY
PRECISION TOOLS
DEBURRING
COOLANT/FLUIDS
TOOL STORAGE

LAYDOWN THREAD TURNING INSERTS

UN FULL PROFILE INSERTS
 For American Unified 60° Threads
 ANSI B1.1:74

Carmex
 Precision Tools Ltd.

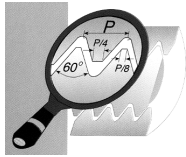

Full Line Available!
 Please call for more information

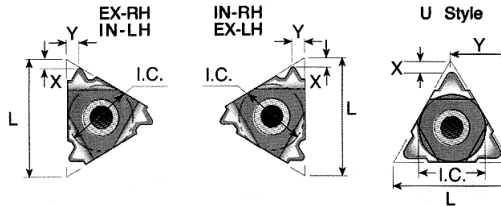

INSERT SERIES	I.C.	Pitch TPI	EXTERNAL				INTERNAL				Price Each
			X	Y	Right Hand Part Number	Left Hand Part Number	X	Y	Right Hand Part Number	Left Hand Part Number	
6	5/32	32	-	-	-	-	.03	.02	T-C06IR32UN	T-C06IL32UN	\$13.98
	5/32	28	-	-	-	-	.03	.02	T-C06IR28UN	T-C06IL28UN	\$13.98
	5/32	24	-	-	-	-	.03	.02	T-C06IR24UN	T-C06IL24UN	\$13.98
	5/32	20	-	-	-	-	.02	.02	T-C06IR20UN	T-C06IL20UN	\$13.98
	5/32	18	-	-	-	-	.02	.03	T-C06IR18UN	T-C06IL18UN	\$13.98
8	3/16	32	-	-	-	-	.02	.02	T-C08IR32UN	T-C08IL32UN	\$13.98
	3/16	28	-	-	-	-	.02	.02	T-C08IR28UN	T-C08IL28UN	\$13.98
	3/16	24	-	-	-	-	.02	.02	T-C08IR24UN	T-C08IL24UN	\$13.98
	3/16	20	-	-	-	-	.02	.03	T-C08IR20UN	T-C08IL20UN	\$13.98
	3/16	18	-	-	-	-	.02	.03	T-C08IR18UN	T-C08IL18UN	\$13.98
	3/16	16	-	-	-	-	.02	.03	T-C08IR16UN	T-C08IL16UN	\$13.98
	3/16	14	-	-	-	-	.02	.03	T-C08IR14UN	T-C08IL14UN	\$13.98
8U	3/16U	13	-	-	-	-	.04	.16	T-C08UIRL13UN	T-C08UIRL13UN	\$15.68
	3/16U	12	-	-	-	-	.04	.16	T-C08UIRL12UN	T-C08UIRL12UN	\$15.68
	3/16U	11	-	-	-	-	.04	.16	T-C08UIRL11UN	T-C08UIRL11UN	\$15.68
11	1/4	72	.03	.02	T-C11ER72UN	T-C11EL72UN	.03	.01	T-C11IR72UN	T-C11IL72UN	\$13.98
	1/4	64	.03	.02	T-C11ER64UN	T-C11EL64UN	.03	.02	T-C11IR64UN	T-C11IL64UN	\$13.98
	1/4	56	.03	.02	T-C11ER56UN	T-C11EL56UN	.03	.02	T-C11IR56UN	T-C11IL56UN	\$13.98
	1/4	48	.02	.02	T-C11ER48UN	T-C11EL48UN	.02	.02	T-C11IR48UN	T-C11IL48UN	\$13.98
	1/4	44	.02	.02	T-C11ER44UN	T-C11EL44UN	.02	.02	T-C11IR44UN	T-C11IL44UN	\$13.98
	1/4	40	.02	.02	T-C11ER40UN	T-C11EL40UN	.02	.02	T-C11IR40UN	T-C11IL40UN	\$13.98
	1/4	36	.02	.02	T-C11ER36UN	T-C11EL36UN	.02	.02	T-C11IR36UN	T-C11IL36UN	\$13.98
	1/4	32	.02	.02	T-C11ER32UN	T-C11EL32UN	.02	.02	T-C11IR32UN	T-C11IL32UN	\$13.98
	1/4	28	.02	.03	T-C11ER28UN	T-C11EL28UN	.02	.03	T-C11IR28UN	T-C11IL28UN	\$13.98
	1/4	27	.03	.03	T-C11ER27UN	T-C11EL27UN	.03	.03	T-C11IR27UN	T-C11IL27UN	\$13.98
	1/4	24	.03	.03	T-C11ER24UN	T-C11EL24UN	.03	.03	T-C11IR24UN	T-C11IL24UN	\$13.98
	1/4	20	.03	.04	T-C11ER20UN	T-C11EL20UN	.03	.04	T-C11IR20UN	T-C11IL20UN	\$13.98
	1/4	18	.03	.04	T-C11ER18UN	T-C11EL18UN	.03	.04	T-C11IR18UN	T-C11IL18UN	\$13.98
	1/4	16	.04	.04	T-C11ER16UN	T-C11EL16UN	.04	.04	T-C11IR16UN	T-C11IL16UN	\$13.98
	1/4	14	.04	.04	T-C11ER14UN	T-C11EL14UN	.04	.04	T-C11IR14UN	T-C11IL14UN	\$13.98
1/4	13	-	-	-	-	.03	.04	T-C11IR13UN	T-C11IL13UN	\$13.98	
1/4	12	-	-	-	-	.04	.04	T-C11IR12UN	T-C11IL12UN	\$13.98	
1/4	11	-	-	-	-	.03	.04	T-C11IR11UN	T-C11IL11UN	\$13.98	
16	3/8	72	.03	.02	T-C16ER72UN	T-C16EL72UN	.03	.01	T-C16IR72UN	T-C16IL72UN	\$13.98
	3/8	64	.03	.02	T-C16ER64UN	T-C16EL64UN	.03	.02	T-C16IR64UN	T-C16IL64UN	\$13.98
	3/8	56	.03	.02	T-C16ER56UN	T-C16EL56UN	.03	.02	T-C16IR56UN	T-C16IL56UN	\$13.98
	3/8	48	.02	.02	T-C16ER48UN	T-C16EL48UN	.02	.02	T-C16IR48UN	T-C16IL48UN	\$13.98
	3/8	44	.02	.02	T-C16ER44UN	T-C16EL44UN	.02	.02	T-C16IR44UN	T-C16IL44UN	\$13.98
	3/8	40	.02	.02	T-C16ER40UN	T-C16EL40UN	.02	.02	T-C16IR40UN	T-C16IL40UN	\$13.98
	3/8	36	.02	.02	T-C16ER36UN	T-C16EL36UN	.02	.02	T-C16IR36UN	T-C16IL36UN	\$13.98
	3/8	32	.02	.02	T-C16ER32UN	T-C16EL32UN	.02	.02	T-C16IR32UN	T-C16IL32UN	\$13.98
	3/8	28	.02	.03	T-C16ER28UN	T-C16EL28UN	.02	.03	T-C16IR28UN	T-C16IL28UN	\$13.98
	3/8	27	.03	.03	T-C16ER27UN	T-C16EL27UN	.03	.03	T-C16IR27UN	T-C16IL27UN	\$13.98
	3/8	24	.03	.03	T-C16ER24UN	T-C16EL24UN	.03	.03	T-C16IR24UN	T-C16IL24UN	\$13.98
	3/8	20	.03	.04	T-C16ER20UN	T-C16EL20UN	.03	.04	T-C16IR20UN	T-C16IL20UN	\$13.98
	3/8	18	.03	.04	T-C16ER18UN	T-C16EL18UN	.03	.04	T-C16IR18UN	T-C16IL18UN	\$13.98
	3/8	16	.04	.04	T-C16ER16UN	T-C16EL16UN	.04	.04	T-C16IR16UN	T-C16IL16UN	\$13.98
	3/8	14	.04	.05	T-C16ER14UN	T-C16EL14UN	.04	.05	T-C16IR14UN	T-C16IL14UN	\$13.98
3/8	13	.04	.05	T-C16ER13UN	T-C16EL13UN	.04	.05	T-C16IR13UN	T-C16IL13UN	\$13.98	
3/8	12	.04	.06	T-C16ER12UN	T-C16EL12UN	.04	.06	T-C16IR12UN	T-C16IL12UN	\$13.98	
3/8	11.5	.04	.06	T-C16ER115UN	T-C16EL115UN	.04	.06	T-C16IR115UN	T-C16IL115UN	\$13.98	
3/8	11	.04	.06	T-C16ER11UN	T-C16EL11UN	.04	.06	T-C16IR11UN	T-C16IL11UN	\$13.98	
3/8	10	.04	.06	T-C16ER10UN	T-C16EL10UN	.04	.06	T-C16IR10UN	T-C16IL10UN	\$13.98	
3/8	9	.05	.07	T-C16ER9UN	T-C16EL9UN	.05	.07	T-C16IR9UN	T-C16IL9UN	\$13.98	
3/8	8	.05	.06	T-C16ER8UN	T-C16EL8UN	.04	.06	T-C16IR8UN	T-C16IL8UN	\$13.98	
22	1/2	7	.06	.09	T-C22ER7UN	T-C22EL7UN	.06	.09	T-C22IR7UN	T-C22IL7UN	\$16.45
	1/2	6	.06	.09	T-C22ER6UN	T-C22EL6UN	.06	.09	T-C22IR6UN	T-C22IL6UN	\$16.45
	1/2	5	.07	.10	T-C22ER5UN	T-C22EL5UN	.06	.09	T-C22IR5UN	T-C22IL5UN	\$16.45
22U	1/2U	4.5	.08	.43	T-C22UERL45UN	T-C22UERL45UN	.09	.43	T-C22UIRL45UN	T-C22UIRL45UN	\$16.45
	1/2U	4	.08	.43	T-C22UERL4UN	T-C22UERL4UN	.09	.43	T-C22UIRL4UN	T-C22UIRL4UN	\$16.45
27	5/8	4.5	.07	.11	T-C27ER45UN	T-C27EL45UN	.07	.09	T-C27IR45UN	T-C27IL45UN	\$26.33
	5/8	4	.08	.12	T-C27ER4UN	T-C27EL4UN	.07	.11	T-C27IR4UN	T-C27IL4UN	\$26.33
27U	5/8U	3	.10	.54	T-C27UERL3UN	T-C27UERL3UN	.11	.54	T-C27UIRL3UN	T-C27UIRL3UN	\$26.33

Call Us Today For All Of Your Machine Tool Needs!

CHUCK JAWS
LATHÉ WORKHOLDING

MACHINE VISES
VISE JAWS

RETENTION KNOBS
ER, DA, TG COLLETS

TOOLHOLDERS
TAP HOLDERS

INDEXABLE DRILLS
TURNING & BORING

ENDMILLS, DRILLS
TAPS & REAMERS

ABRASIVES
MEASURING TOOLS

MRO & SAFETY
FLAT STOCK/DRILL ROD

UN FULL PROFILE INSERTS

With Sintered Chipbreaker
For American Unified 60° Threads
ANSI B1.1:74

Carmex
Precision Tools Ltd.

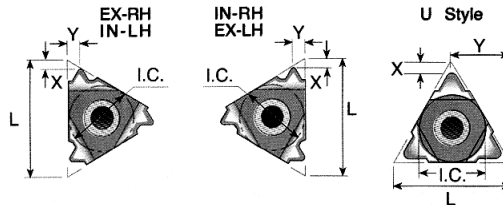
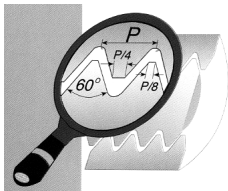

INSERT SERIES	I.C.	PITCH TPI	X	Y	EXTERNAL		X	Y	INTERNAL		Price Each
					Right Hand Part Number	Left Hand Part Number			Right Hand Part Number	Left Hand Part Number	
16	3/8	24	.03	.03	T-C16ERB24UN__	T-C16ELB24UN__	.03	.03	T-C16IRB24UN__	T-C16ILB24UN__	\$13.98
	3/8	20	.03	.04	T-C16ERB20UN__	T-C16ELB20UN__	.03	.04	T-C16IRB20UN__	T-C16ILB20UN__	\$13.98
	3/8	18	.03	.04	T-C16ERB18UN__	T-C16ELB18UN__	.03	.04	T-C16IRB18UN__	T-C16ILB18UN__	\$13.98
	3/8	16	.04	.04	T-C16ERB16UN__	T-C16ELB16UN__	.04	.04	T-C16IRB16UN__	T-C16ILB16UN__	\$13.98
	3/8	14	.04	.05	T-C16ERB14UN__	T-C16ELB14UN__	.04	.05	T-C16IRB14UN__	T-C16ILB14UN__	\$13.98
	3/8	13	.04	.05	T-C16ERB13UN__	T-C16ELB13UN__	-	-	-	-	\$13.98
	3/8	12	.04	.06	T-C16ERB12UN__	T-C16ELB12UN__	.04	.06	T-C16IRB12UN__	T-C16ILB12UN__	\$13.98
	3/8	11	.04	.06	T-C16ERB11UN__	T-C16ELB11UN__	-	-	-	-	\$13.98
	3/8	10	.04	.06	T-C16ERB10UN__	T-C16ELB10UN__	.04	.06	T-C16IRB10UN__	T-C16ILB10UN__	\$13.98
	3/8	9	.05	.07	T-C16ERB9UN__	T-C16ELB9UN__	-	-	-	-	\$13.98
3/8	8	.05	.06	T-C16ERB8UN__	T-C16ELB8UN__	.04	.06	T-C16IRB8UN__	T-C16ILB8UN__	\$13.98	

UNJ, UNJC, UNJF, UNJEF, UNJS INSERTS

Aerospace Threads-Controlled Root Radius

Carmex
Precision Tools Ltd.

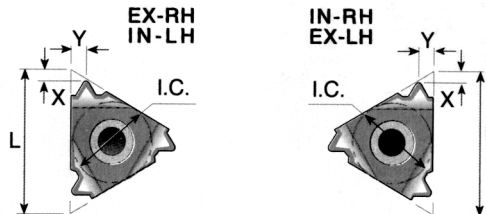
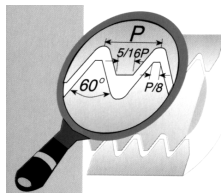

INSERT SERIES	I.C.	PITCH TPI	X	Y	EXTERNAL		INTERNAL		Price Each
					Right Hand Part Number	Left Hand Part Number	Right Hand Part Number	Left Hand Part Number	
11	1/4	48	.02	.02	T-C11ER48UNJ__	T-C11EL48UNJ__	T-C11IR48UNJ__	T-C11IL48UNJ__	\$16.45
	1/4	44	.02	.02	T-C11ER44UNJ__	T-C11EL44UNJ__	T-C11IR44UNJ__	T-C11IL44UNJ__	\$16.45
	1/4	40	.02	.02	T-C11ER40UNJ__	T-C11EL40UNJ__	T-C11IR40UNJ__	T-C11IL40UNJ__	\$16.45
	1/4	36	.02	.02	T-C11ER36UNJ__	T-C11EL36UNJ__	T-C11IR36UNJ__	T-C11IL36UNJ__	\$16.45
	1/4	32	.02	.02	T-C11ER32UNJ__	T-C11EL32UNJ__	T-C11IR32UNJ__	T-C11IL32UNJ__	\$16.45
	1/4	28	.02	.02	T-C11ER28UNJ__	T-C11EL28UNJ__	T-C11IR28UNJ__	T-C11IL28UNJ__	\$16.45
	1/4	24	.03	.03	T-C11ER24UNJ__	T-C11EL24UNJ__	T-C11IR24UNJ__	T-C11IL24UNJ__	\$16.45
	1/4	20	.03	.04	T-C11ER20UNJ__	T-C11EL20UNJ__	T-C11IR20UNJ__	T-C11IL20UNJ__	\$16.45
	1/4	18	.03	.04	T-C11ER18UNJ__	T-C11EL18UNJ__	T-C11IR18UNJ__	T-C11IL18UNJ__	\$16.45
	1/4	16	.03	.04	T-C11ER16UNJ__	T-C11EL16UNJ__	T-C11IR16UNJ__	T-C11IL16UNJ__	\$16.45
1/4	14	.04	.04	T-C11ER14UNJ__	T-C11EL14UNJ__	T-C11IR14UNJ__	T-C11IL14UNJ__	\$16.45	
16	3/8	48	.02	.02	T-C16ER48UNJ__	T-C16EL48UNJ__	T-C16IR48UNJ__	T-C16IL48UNJ__	\$16.45
	3/8	44	.02	.02	T-C16ER44UNJ__	T-C16EL44UNJ__	T-C16IR44UNJ__	T-C16IL44UNJ__	\$16.45
	3/8	40	.02	.02	T-C16ER40UNJ__	T-C16EL40UNJ__	T-C16IR40UNJ__	T-C16IL40UNJ__	\$16.45
	3/8	36	.02	.02	T-C16ER36UNJ__	T-C16EL36UNJ__	T-C16IR36UNJ__	T-C16IL36UNJ__	\$16.45
	3/8	32	.02	.02	T-C16ER32UNJ__	T-C16EL32UNJ__	T-C16IR32UNJ__	T-C16IL32UNJ__	\$16.45
	3/8	28	.02	.02	T-C16ER28UNJ__	T-C16EL28UNJ__	T-C16IR28UNJ__	T-C16IL28UNJ__	\$16.45
	3/8	24	.03	.03	T-C16ER24UNJ__	T-C16EL24UNJ__	T-C16IR24UNJ__	T-C16IL24UNJ__	\$16.45
	3/8	20	.03	.04	T-C16ER20UNJ__	T-C16EL20UNJ__	T-C16IR20UNJ__	T-C16IL20UNJ__	\$16.45
	3/8	18	.03	.04	T-C16ER18UNJ__	T-C16EL18UNJ__	T-C16IR18UNJ__	T-C16IL18UNJ__	\$16.45
	3/8	16	.03	.04	T-C16ER16UNJ__	T-C16EL16UNJ__	T-C16IR16UNJ__	T-C16IL16UNJ__	\$16.45
	3/8	14	.04	.05	T-C16ER14UNJ__	T-C16EL14UNJ__	T-C16IR14UNJ__	T-C16IL14UNJ__	\$16.45
	3/8	13	.04	.05	T-C16ER13UNJ__	T-C16EL13UNJ__	T-C16IR13UNJ__	T-C16IL13UNJ__	\$16.45
	3/8	12	.04	.06	T-C16ER12UNJ__	T-C16EL12UNJ__	T-C16IR12UNJ__	T-C16IL12UNJ__	\$16.45
	3/8	11	.04	.06	T-C16ER11UNJ__	T-C16EL11UNJ__	T-C16IR11UNJ__	T-C16IL11UNJ__	\$16.45
3/8	10	.04	.06	T-C16ER10UNJ__	T-C16EL10UNJ__	T-C16IR10UNJ__	T-C16IL10UNJ__	\$16.45	
3/8	9	.05	.06	T-C16ER9UNJ__	T-C16EL9UNJ__	T-C16IR9UNJ__	T-C16IL9UNJ__	\$16.45	
3/8	8	.05	.06	T-C16ER8UNJ__	T-C16EL8UNJ__	T-C16IR8UNJ__	T-C16IL8UNJ__	\$16.45	

Call Us Or Visit Our Website For Our Complete Selection!

LATHE CHUCKS
LIVE CENTERS
VISE JAWS
VISE ACCESSORIES
STRAIGHT SHANK
COLLET HOLDERS
TAP HOLDERS
DRILL CHUCKS
CARBIDE INSERTS
THREADING/GROOVING
CUTTING TOOLS
MACHINERY
PRECISION TOOLS
DEBURRING
COOLANT/FLUIDS
TOOL STORAGE

LAYDOWN THREAD TURNING INSERTS

NPT-USAS B2.1:1968 INSERTS

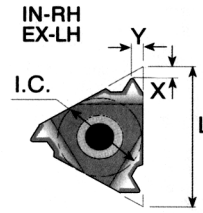
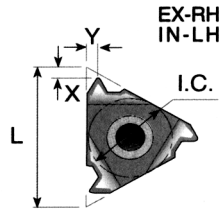
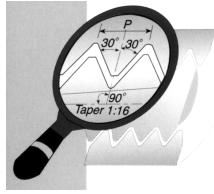

Carmex
Precision Tools Ltd.

INSERT SERIES	I.C.	PITCH TPI	X	Y	EXTERNAL		INTERNAL		Price Each
					Right Hand Part Number	Left Hand Part Number	Right Hand Part Number	Left Hand Part Number	
6	5/32	27	.02	.02	-	-	T-C06IR27NPT__	T-C06IL27NPT__	\$13.98
		18	.02	.02	-	-	T-C08IR27NPT__	T-C08IL27NPT__	\$13.98
8	3/16	18	.02	.02	-	-	T-C08IR18NPT__	T-C08IL18NPT__	\$13.98
		14	.03	.04	T-C11ER27NPT__	T-C11EL27NPT__	T-C11IR27NPT__	T-C11IL27NPT__	\$13.98
		14	.03	.04	T-C11ER18NPT__	T-C11EL18NPT__	T-C11IR18NPT__	T-C11IL18NPT__	\$13.98
11	1/4	27	.03	.03	T-C11ER14NPT__	T-C11EL14NPT__	T-C11IR14NPT__	T-C11IL14NPT__	\$13.98
		18	.03	.04	T-C16ER27NPT__	T-C16EL27NPT__	T-C16IR27NPT__	T-C16IL27NPT__	\$13.98
		18	.03	.04	T-C16ER18NPT__	T-C16EL18NPT__	T-C16IR18NPT__	T-C16IL18NPT__	\$13.98
		14	.04	.05	T-C16ER14NPT__	T-C16EL14NPT__	T-C16IR14NPT__	T-C16IL14NPT__	\$13.98
		11.5	.04	.06	T-C16ER11.5NPT__	T-C16EL11.5NPT__	T-C16IR11.5NPT__	T-C16IL11.5NPT__	\$13.98
16	3/8	8	.05	.07	T-C16ER8NPT__	T-C16EL8NPT__	T-C16IR8NPT__	T-C16IL8NPT__	\$13.98

NPT / W CHIPBREAKER

16	3/8	18	.03	.04	T-C16ERB18NPT__	T-C16ELB18NPT__	-	-	\$13.98
		14	.04	.05	T-C16ERB14NPT__	T-C16ELB14NPT__	T-C16IRB14NPT__	T-C16ILB14NPT__	\$13.98
		11.5	.04	.06	T-C16ERB11.5NPT__	T-C16ELB11.5NPT__	T-C16IRB11.5NPT__	T-C16ILB11.5NPT__	\$13.98
		8	.05	.07	T-C16ERB8NPT__	T-C16ELB8NPT__	T-C16IRB8NPT__	T-C16ILB8NPT__	\$13.98

NPTF DRYSEAL INSERTS ANSI B1.20.3-1976

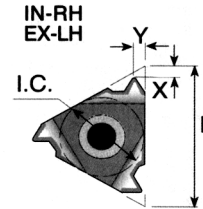
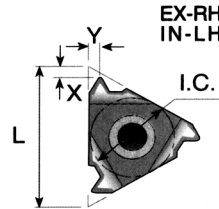
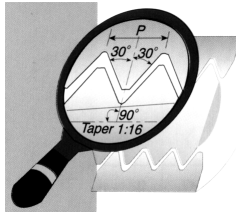

Carmex
Precision Tools Ltd.

INSERT SERIES	I.C.	PITCH TPI	X	Y	EXTERNAL		INTERNAL		Price Each
					Right Hand Part Number	Left Hand Part Number	Right Hand Part Number	Left Hand Part Number	
6	5/32	27	.03	.02	-	-	T-C06IR27NPF__	T-C06IL27NPF__	\$13.98
8	3/16	27	.02	.02	-	-	T-C08IR27NPF__	T-C08IL27NPF__	\$13.98
		18	.02	.02	-	-	T-C08IR18NPF__	T-C08IL18NPF__	\$13.98
11	1/4	27	.03	.03	T-C11ER27NPF__	T-C11EL27NPF__	T-C11IR27NPF__	T-C11IL27NPF__	\$13.98
		18	.03	.04	T-C11ER18NPF__	T-C11EL18NPF__	T-C11IR18NPF__	T-C11IL18NPF__	\$13.98
		14	.03	.04	T-C11ER14NPF__	T-C11EL14NPF__	T-C11IR14NPF__	T-C11IL14NPF__	\$13.98
16	3/8	27	.03	.03	T-C16ER27NPF__	T-C16EL27NPF__	T-C16IR27NPF__	T-C16IL27NPF__	\$13.98
		18	.03	.04	T-C16ER18NPF__	T-C16EL18NPF__	T-C16IR18NPF__	T-C16IL18NPF__	\$13.98
		14	.04	.05	T-C16ER14NPF__	T-C16EL14NPF__	T-C16IR14NPF__	T-C16IL14NPF__	\$13.98
		11.5	.04	.06	T-C16ER11.5NPF__	T-C16EL11.5NPF__	T-C16IR11.5NPF__	T-C16IL11.5NPF__	\$13.98
		8	.05	.07	T-C16ER8NPF__	T-C16EL8NPF__	T-C16IR8NPF__	T-C16IL8NPF__	\$13.98

GRADE INFORMATION

Carmex
Precision Tools Ltd.

CARMEX GRADE INFORMATION

How To Order:

- 1) Pick the required insert from table above eg: T-C11ERA60__
- 2) Pick a Carbide grade from the Grades table below - eg. B4 for superalloys and stainless steels
- 3) Order Part Number T-C11ERA60B4
- 4) Pick toolholder (ext) or boring bar (int) from pages 322-323

Carmex Grade	USST Grade	Carbide ANSI	Coating	Materials
P25C	P5	C5	TIN	Hard Steels
MXC	M2	C2-C3	TIN	Soft Steels, Stainless Steels, Cast Iron
BMA	B4	C3-C4	TIALN	Superalloys, Stainless Steels
K20	K2	C2	UNCOATED	Aluminum, Non Ferrous

Call Us Today For All Of Your Machine Tool Needs!

ACME 29° THREAD INSERTS

Carmex
Precision Tools Ltd.

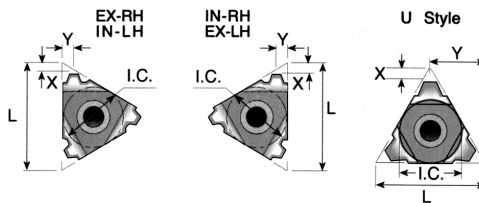
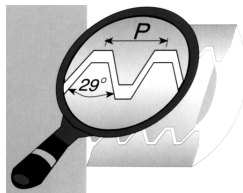

INSERT SERIES	I.C.	PITCH TPI	X	Y	EXTERNAL		INTERNAL		Price Each
					Right Hand Part Number	Left Hand Part Number	Right Hand Part Number	Left Hand Part Number	
8	3/16	16	.02	.02	-	-	T-C08IR16ACM	T-C08IL16ACM	\$16.45
8U	3/16U	14	.03	.16	-	-	T-C08UIRL14ACM	T-C08UIRL14ACM	\$16.45
	3/16U	12	.03	.16	-	-	T-C08UIRL12ACM	T-C08UIRL12ACM	\$16.45
	3/16U	10	.03	.16	-	-	T-C08UIRL10ACM	T-C08UIRL10ACM	\$16.45
11	1/4	16	.04	.04	T-C11ER16ACM	T-C11EL16ACM	-	-	\$16.45
16	3/8	16	.04	.04	T-C16ER16ACM	T-C16EL16ACM	-	-	\$16.45
	3/8	14	.04	.05	T-C16ER14ACM	T-C16EL14ACM	T-C16IR14ACM	T-C16IL14ACM	\$16.45
	3/8	12	.04	.05	T-C16ER12ACM	T-C16EL12ACM	T-C16IR12ACM	T-C16IL12ACM	\$16.45
	3/8	10	.05	.05	T-C16ER10ACM	T-C16EL10ACM	T-C16IR10ACM	T-C16IL10ACM	\$16.45
	3/8	8	.06	.06	T-C16ER8ACM	T-C16EL8ACM	T-C16IR8ACM	T-C16IL8ACM	\$16.45
22	1/2	6	.07	.08	T-C22ER6ACM	T-C22EL6ACM	T-C22IR6ACM	T-C22IL6ACM	\$20.57
	1/2	5	.08	.09	T-C22ER5ACM	T-C22EL5ACM	T-C22IR5ACM	T-C22IL5ACM	\$20.57
22U	1/2U	4	.09	.43	T-C22UERL4ACM	T-C22UERL4ACM	T-C22UIRL4ACM	T-C22UIRL4ACM	\$20.57
27	5/8	4	.09	.11	T-C27ER4ACM	T-C27EL4ACM	T-C27IR4ACM	T-C27IL4ACM	\$27.15
27U	5/8U	3	.11	.54	T-C27UERL3ACM	T-C27UERL3ACM	T-C27UIRL3ACM	T-C27UIRL3ACM	\$27.15
33U	3/4U	2	.17	.67	T-C33UERL2ACM	T-C33UERL2ACM	T-C33UIRL2ACM	T-C33UIRL2ACM	\$111.86

STUB ACME 29° THREAD INSERTS

INSERT SERIES	I.C.	PITCH TPI	X	Y	EXTERNAL		INTERNAL		Price Each
					Right Hand Part Number	Left Hand Part Number	Right Hand Part Number	Left Hand Part Number	
8	3/16	16	.02	.02	-	-	T-C08IR16SAC	T-C08IL16SAC	\$16.45
8U	3/16U	14	.03	.16	-	-	T-C08UIR/L14SAC	T-C08UIR/L14SAC	\$16.45
	3/16U	12	.04	.16	-	-	T-C08UIR/L12SAC	T-C08UIR/L12SAC	\$16.45
	3/16U	10	.04	.16	-	-	T-C08UIR/L10SAC	T-C08UIR/L10SAC	\$16.45
11	1/4	16	.04	.04	T-C11ER16SAC	T-C11EL16SAC	-	-	\$16.45
16	3/8	16	.04	.04	T-C16ER16SAC	T-C16EL16SAC	-	-	\$16.45
	3/8	14	.04	.04	T-C16ER14SAC	T-C16EL14SAC	T-C16IR14SAC	T-C16IL14SAC	\$16.45
	3/8	12	.05	.05	T-C16ER12SAC	T-C16EL12SAC	T-C16IR12SAC	T-C16IL12SAC	\$16.45
	3/8	10	.05	.05	T-C16ER10SAC	T-C16EL10SAC	T-C16IR10SAC	T-C16IL10SAC	\$16.45
	3/8	8	.06	.06	T-C16ER8SAC	T-C16EL8SAC	T-C16IR8SAC	T-C16IL8SAC	\$16.45
3/8	6	.07	.07	T-C16ER6SAC	T-C16EL6SAC	T-C16IR6SAC	T-C16IL6SAC	\$16.45	
22	1/2	5	.08	.09	T-C22ER5SAC	T-C22EL5SAC	T-C22IR5SAC	T-C22IL5SAC	\$20.57
22U	1/2U	4	.10	.43	T-C22UER/L4SAC	T-C22UER/L4SAC	T-C22UIR/L4SAC	T-C22UIR/L4SAC	\$20.57
	1/2U	3	.13	.43	T-C22UER/L3SAC	T-C22UER/L3SAC	T-C22UIR/L3SAC	T-C22UIR/L3SAC	\$20.57
27	5/8	4	.09	.09	T-C27ER4SAC	T-C27EL4SAC	T-C27IR4SAC	T-C27IL4SAC	\$27.15
	5/8	3	.11	.11	T-C27ER3SAC	T-C27EL3SAC	T-C27IR3SAC	T-C27IL3SAC	\$27.15
33U	3/4U	2	.20	.67	T-C33UER/L2SAC	T-C33UER/L2SAC	T-C33UIR/L2SAC	T-C33UIR/L2SAC	\$111.86

AMERICAN BUTTRESS THREAD INSERTS

Carmex
Precision Tools Ltd.

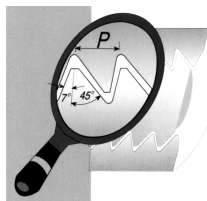

Full Line Available!
Please call for more information.

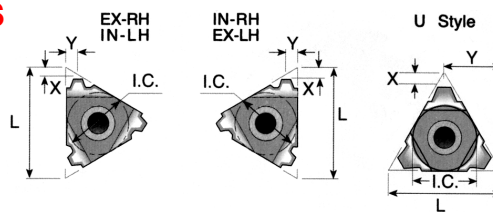

INSERT SERIES	I.C.	PITCH TPI	X	Y	EXTERNAL		INTERNAL		Price Each
					Right Hand Part Number	Left Hand Part Number	Right Hand Part Number	Left Hand Part Number	
11	1/4	20	.04	.05	T-C11ER20ABUT	T-C11EL20ABUT	T-C11IR20ABUT	T-C11IL20ABUT	\$16.45
	1/4	16	.04	.06	T-C11ER16ABUT	T-C11EL16ABUT	T-C11IR16ABUT	T-C11IL16ABUT	\$16.45
16	3/8	20	.04	.05	T-C16ER20ABUT	T-C16EL20ABUT	T-C16IR20ABUT	T-C16IL20ABUT	\$16.45
	3/8	16	.04	.06	T-C16ER16ABUT	T-C16EL16ABUT	T-C16IR16ABUT	T-C16IL16ABUT	\$16.45
	3/8	12	.06	.08	T-C16ER12ABUT	T-C16EL12ABUT	T-C16IR12ABUT	T-C16IL12ABUT	\$16.45
	3/8	10	.06	.09	T-C16ER10ABUT	T-C16EL10ABUT	T-C16IR10ABUT	T-C16IL10ABUT	\$16.45
22	1/2	8	.08	.13	T-C22ER8ABUT	T-C22EL8ABUT	T-C22IR8ABUT	T-C22IL8ABUT	\$20.57
	1/2	6	.08	.13	T-C22ER6ABUT	T-C22EL6ABUT	T-C22IR6ABUT	T-C22IL6ABUT	\$20.57
22U	1/2U	4	.09	.37	T-C22UER4ABUT	T-C22UEL4ABUT	T-C22UIR4ABUT	T-C22UIL4ABUT	\$20.57
27U	5/8U	3	.12	.46	T-C27UER3ABUT	T-C27UEL3ABUT	T-C27UIR3ABUT	T-C27UIL3ABUT	\$27.15

Call Us Or Visit Our Website For Our Complete Selection!

LATHE CHUCKS
LIVE CENTERS
VISE ACCESSORIES
VISE JAWS
STRAIGHT SHANK COLLET HOLDERS
TAP HOLDERS
DRILL CHUCKS
CARBIDE INSERTS
THREADING/GROOVING
CUTTING TOOLS
MACHINERY
PRECISION TOOLS
DEBURRING
COOLANT/FLUIDS
TOOL STORAGE

LAYDOWN THREAD TURNING INSERTS & HOLDERS

OIL THREAD INSERTS

Carmex
Precision Tools Ltd.

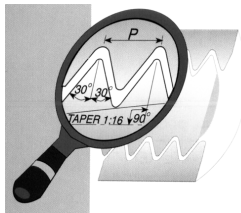

API Round

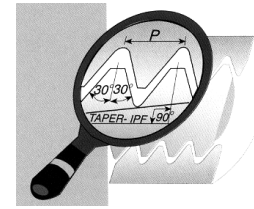
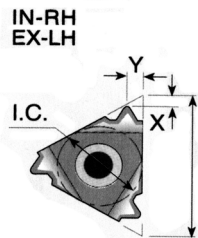
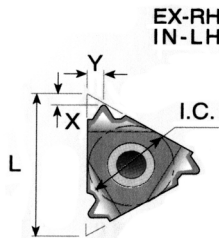

Oil V40

INSERT SERIES	I.C.	PITCH TPI	X	Y	CONNECTION No.or Size	TAPER IPF	EXTERNAL		INTERNAL		Price Each
							Right Hand Part Number	Left Hand Part Number	Right Hand Part Number	Left Hand Part Number	
API ROUND											
16	3/8	10	.06	.06	-	0.75	T-C16ER10APR__	T-C16EL10APR__	T-C16IR10APR__	T-C16IL10APR__	\$16.45
	3/8	8	.05	.06	-	0.75	T-C16ER8APR__	T-C16EL8APR__	T-C16IR8APR__	T-C16IL8APR__	\$16.45
APIV-0.040											
22	1/2	5	.07	.10	23/8 - 41/2 REG	3	T-C22ER5AP403__	T-C22EL5AP403__	T-C22IR5AP403__	T-C22IL5AP403__	\$23.45
APIV-0.038R											
27	5/8	4	.08	.08	NC23-NC50	2	T-C27ER4AP382__	T-C27EL4AP382__	T-C27IR4AP382__	T-C27IL4AP382__	\$27.15
	5/8	4	.08	.11	NC56-NC77	3	T-C27ER4AP383__	T-C27EL4AP383__	T-C27IR4AP383__	T-C27IL4AP383__	\$27.15
APIV-0.050R											
27	5/8	4	.08	.12	65/8 REG	2	T-C27ER4AP502__	T-C27EL4AP502__	T-C27IR4AP502__	T-C27IL4AP502__	\$27.15
	5/8	4	.08	.12	51/2, 75/8, 85/8 REG	3	T-C27ER4AP503__	T-C27EL4AP503__	T-C27IR4AP503__	T-C27IL4AP503__	\$27.15

TOOLHOLDERS FOR EXTERNAL LAYDOWN THREAD TURNING

Carmex
Precision Tools Ltd.

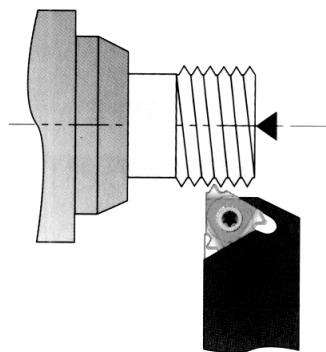
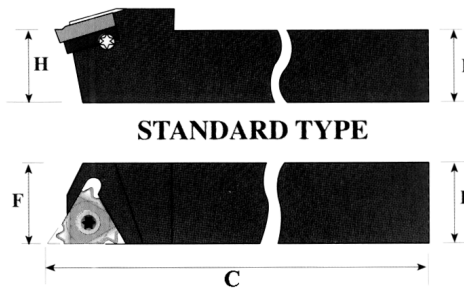

HOLDER SERIES	B=H in	C in OAL	F in	EXTERNAL		Price Each
				Right Handed Part Number	Left Handed Part Number	
11	0.380	4.000	0.430	T-CMSER0375H11	T-CMSEL0375H11	\$82.50
16	0.380	2.500	0.630	T-CMSER0375D16	T-CMSEL0375D16	\$82.50
	0.500	3.250	0.630	T-CMSER0500F16	T-CMSEL0500F16	\$82.50
	0.630	4.000	0.630	T-CMSER0625H16	T-CMSEL0625H16	\$82.50
	0.750	5.000	0.750	T-CMSER0750K16	T-CMSEL0750K16	\$82.50
	1.000	6.000	1.000	T-CMSER1000M16	T-CMSEL1000M16	\$82.50
22	1.250	7.000	1.250	T-CMSER1250P16	T-CMSEL1250P16	\$110.00
	1.000	6.000	1.000	T-CMSER1000M22	T-CMSEL1000M22	\$105.42
	1.250	7.000	1.250	T-CMSER1250P22	T-CMSEL1250P22	\$115.50
22U	1.500	8.000	1.500	T-CMSER1500R22	T-CMSEL1500R22	\$160.42
	1.000	6.000	1.100	T-CMSER1000M22U	T-CMSEL1000M22U	\$105.42
	1.250	7.000	1.250	T-CMSER1250P22U	T-CMSEL1250P22U	\$115.50
27	1.000	6.000	1.250	T-CMSER1000M27	T-CMSEL1000M27	\$115.50
	1.250	7.000	1.250	T-CMSER1250P27	T-CMSEL1250P27	\$134.75
27U	1.000	6.000	1.250	T-CMSER1000M27U	T-CMSEL1000M27U	\$134.75
	1.250	7.000	1.250	T-CMSER1250P27U	T-CMSEL1250P27U	\$134.75
	1.500	8.000	1.500	T-CMSER1500R27U	T-CMSEL1500R27U	\$160.42
33U	1.250	7.000	1.450	T-CMSER1250P33U	T-CMSEL1250P33U	\$183.33

Full Line Available!
Please call for more information.

Important Notes: Use External Right Handed Holders with External Right Handed Laydown Inserts of the same Insert Series only. Similarly for Left Handed Holders and Inserts. Do not interchange insert series or insert hands.

Call Us Today For All Of Your Machine Tool Needs!

LAYDOWN INTERNAL THREADING BORING BARS

B

BORING BARS FOR LAYDOWN INTERNAL THREADING

Carmex
Precision Tools Ltd.

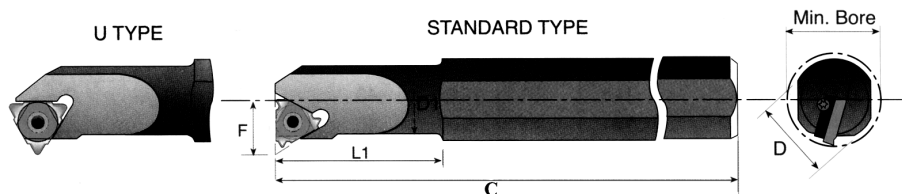

HOLDER SERIES	Min Bore in.	SHANK	Shank D in.	D1 in.	C (OAL) in.	L1 in.	F in.	ANVIL USED	COOLANT THROUGH	INTERNAL		Price Each
										Right Handed Part Number	Left Handed Part Number	
6	0.240	Steel	0.500	0.200	4.000	0.470	0.170	NO	NO	T-CMSIR0205H06	T-CMSIL0205H06	\$125.58
8	0.310	Steel	0.620	0.260	5.000	0.700	0.210	NO	NO	T-CMSIR0265K08	T-CMSIL0265K08	\$115.50
8U	0.350	Steel	0.620	0.290	5.000	0.830	0.260	NO	NO	T-CMSIR0310K08U	T-CMSIL0310K08U	\$125.58
11	0.470	Steel	0.380	0.380	4.000	-	0.280	NO	NO	T-CMSIR0375H11	T-CMSIL0375H11	\$82.50
	0.470	Steel	0.620	0.380	5.000	1.000	0.280	NO	NO	T-CMSIR0375K11	T-CMSIL0375K11	\$82.50
	0.470	Steel	0.620	0.380	5.000	0.980	0.280	YES	YES	T-CMSIR0375K11B	T-CMSIL0375K11B	\$96.25
	0.580	Steel	0.620	0.500	5.500	1.250	0.340	NO	NO	T-CMSIR0500L11	T-CMSIL0500L11	\$82.50
	0.580	Carbide	0.500	0.500	7.000	-	0.340	NO	YES	T-CMSIR0500P11C	T-CMSIL0500P11C	\$357.50
16	0.640	Steel	0.620	0.500	6.000	1.250	0.390	NO	NO	T-CMSIR0500M16	T-CMSIL0500M16	\$91.67
	0.640	Steel	0.620	0.500	6.000	1.260	0.390	YES	YES	T-CMSIR0500M16B	T-CMSIL0500M16B	\$105.42
	0.750	Steel	0.750	0.620	7.000	1.570	0.450	NO	NO	T-CMSIR0625P16	T-CMSIL0625P16	\$91.67
	0.750	Steel	0.750	0.630	7.000	1.570	0.450	YES	YES	T-CMSIR0625P16B	T-CMSIL0625P16B	\$105.42
	0.900	Steel	0.750	0.750	7.000	-	0.510	YES	NO	T-CMSIR0750P16	T-CMSIL0750P16	\$91.67
	0.900	Steel	0.750	0.750	7.000	-	0.900	YES	YES	T-CMSIR0750P16B	T-CMSIL0750P16B	\$115.50
	1.160	Steel	1.000	1.000	8.000	-	0.650	YES	NO	T-CMSIR1000R16	T-CMSIL1000R16	\$128.33
	1.160	Steel	1.000	0.980	8.000	-	0.650	YES	YES	T-CMSIR1000R16B	T-CMSIL1000R16B	\$134.75
22	1.400	Steel	1.250	1.250	10.000	-	0.770	YES	NO	T-CMSIR1250S16	T-CMSIL1250S16	\$128.33
	1.650	Steel	1.500	1.500	12.000	-	0.900	YES	NO	T-CMSIR1500T16	T-CMSIL1500T16	\$155.83
	0.900	Steel	0.750	0.750	7.000	-	0.590	NO	NO	T-CMSIR0750P22	T-CMSIL0750P22	\$91.67
	1.160	Steel	1.000	1.000	8.000	-	0.710	YES	NO	T-CMSIR1000R22	T-CMSIL1000R22	\$134.75
22u	1.500	Steel	1.250	1.250	10.000	-	0.850	YES	NO	T-CMSIR1250S22	T-CMSIL1250S22	\$134.75
	1.750	Steel	1.500	1.500	12.000	-	0.980	YES	NO	T-CMSIR1500T22	T-CMSIL1500T22	\$165.00
27	1.500	Steel	1.250	1.250	10.000	-	0.950	YES	NO	T-CMSIR1250S22U	T-CMSIL1250S22U	\$134.75
	1.750	Steel	1.500	1.500	12.000	-	1.080	YES	NO	T-CMSIR1500T22U	T-CMSIL1500T22U	\$165.00
27u	1.560	Steel	1.250	1.250	10.000	-	0.880	YES	NO	T-CMSIR1250S27	T-CMSIL1250S27	\$165.00
	1.800	Steel	1.500	1.500	12.000	-	1.000	YES	NO	T-CMSIR1500T27	T-CMSIL1500T27	\$165.00
	2.300	Steel	2.000	2.000	14.000	-	1.250	YES	NO	T-CMSIR2000U27	T-CMSIL2000U27	\$261.25
	1.560	Steel	1.250	1.250	10.000	-	1.000	YES	NO	T-CMSIR1250S27U	T-CMSIL1250S27U	\$165.00
	1.800	Steel	1.500	1.500	12.000	-	1.130	YES	NO	T-CMSIR1500T27U	T-CMSIL1500T27U	\$174.17
	2.300	Steel	2.000	2.000	14.000	-	1.370	YES	NO	T-CMSIR2000U27U	T-CMSIL2000U27U	\$261.25
33u	2.800	Steel	2.500	2.500	16.000	-	1.610	YES	NO	T-CMSIR2500V27U	T-CMSIL2500V27U	\$270.42
33u	2.500	Steel	2.000	2.000	14.000	-	1.500	YES	NO	T-CMSIR2000U33U	T-CMSIL2000U33U	\$357.50

Important Notes: Use Internal Right Handed Holders With Internal Right Handed Laydown Inserts Of The Same Insert Series Only. Similarly For Left Handed Holders And Inserts. Do Not Interchange Insert Series Or Insert Hands.

Carmex
Precision Tools Ltd.

CARMEX GRADE INFORMATION



How To Order CARMEX Inserts:

- 1) Pick the required insert from table ex: T-C11ERA60__
- 2) Pick a Carbide grade from the Grades table below - eg. B4 for superalloys and stainless steels
- 3) Order Part Number T-C11ERA60B4
- 4) Pick toolholder (ext) or boring bar (int) from pages 370-371

CARMEX GRADE INFORMATION

Carmex Grade	USST Grade Suffix	Carbide ANSI	Coating	Materials
P25C	P5	C5	TIN	Hard Steels
MXC	M2	C2-C3	TIN	Soft Steels, Stainless Steels, Cast Iron
BMA	B4	C3-C4	TIALN	Superalloys, Stainless Steels
K20	K2	C2	UNCOATED	Aluminum, Non Ferrous

Call Us Or Visit Our Website For Our Complete Selection!

LATHE CHUCKS
LIVE CENTERS
VISE JAWS
VISE ACCESSORIES
STRAIGHT SHANK
COLLET HOLDERS
TAP HOLDERS
DRILL CHUCKS
CARBIDE INSERTS
THREADING/GROOVING
CUTTING TOOLS
MACHINERY
PRECISION TOOLS
DEBURRING
COOLANT/FLUIDS
TOOL STORAGE