

THREADMILLS

SOLID CARBIDE THREADMILLS UN-AMERICAN UNIFIED 60°

Free Programming Help!
Please Call For More Information.

Carmex
Precision Tools Ltd.

Full Line Available!
Please call for more information.

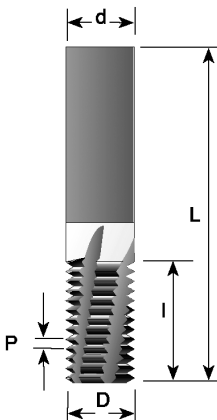

TPI	UNC	UNF	UNEF	d	D	No. of flutes	I	L	Part Number	Price Each
NO COOLANT PASSAGE										
40	5			1/4	.098	3	.24	2.5	T-CT40UN-200	\$168.30
32	8			1/4	.126	3	.27	2.5	T-CT32UN-205	\$168.30
28				1/4	.157	3	.45	2.5	T-CT28UN-210	\$168.30
28			7/16-1/2	1/4	.236	3	.57	2.5	T-CT28UN-215	\$168.30
24		5/16-3/8		1/4	.197	3	.56	2.5	T-CT24UN-220	\$168.30
24			9/16-5/8	5/16	.276	3	.81	2.5	T-CT24UN-225	\$188.10
20	1/4			1/4	.177	3	.48	2.5	T-CT20UN-230	\$168.30
20		7/16-1/2		5/16	.276	3	.83	2.5	T-CT20UN-235	\$188.10
20			3/4-1	1/2	.472	5	1.08	3.0	T-CT20UN-240	\$217.80
18	5/16			1/4	.197	3	.58	2.5	T-CT18UN-245	\$168.30
18		9/16-5/8	11/8-15/8	3/8	.375	4	1.03	3.0	T-CT18UN-250	\$198.00
16	3/8			1/4	.236	3	.66	2.5	T-CT16UN-255	\$168.30
16		3/4		1/2	.472	4	1.22	3.0	T-CT16UN-260	\$217.80
14	7/16			5/16	.276	3	.82	2.5	T-CT14UN-265	\$188.10
14		7/8		5/8	.591	5	1.46	4.0	T-CT14UN-270	\$297.00
13	1/2			5/16	.313	3	.88	2.5	T-CT13UN-275	\$188.10
12	9/16			3/8	.375	3	1.04	3.0	T-CT12UN-280	\$198.00
12		1-11/2		5/8	.625	5	1.63	4.0	T-CT12UN-285	\$297.00
11	5/8			3/8	.375	3	1.14	3.0	T-CT11UN-290	\$198.00
10	3/4			1/2	.472	3	1.35	3.0	T-CT10UN-295	\$217.80
9	7/8			5/8	.591	3	1.50	4.0	T-CT9UN-300	\$297.00
8	1			5/8	.625	3	1.69	4.0	T-CT8UN-305	\$297.00
7	11/8-11/4			3/4	.750	4	1.78	4.0	T-CT7UN-310	\$405.90

WITH THRU COOLANT HOLE

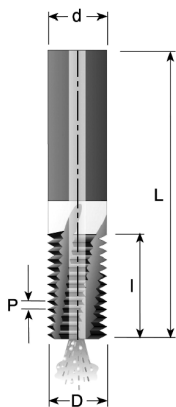

32	8	10	12	1/4	.126	3	.27	2.5	T-CT32UN-315C	\$168.30
28		1/4		1/4	.197	3	.44	2.5	T-CT28UN-320C	\$168.30
28			7/16-1/2	1/4	.250	3	.56	2.5	T-CT28UN-325C	\$168.30
24		5/16		5/16	.260	3	.56	2.5	T-CT24UN-330C	\$188.10
24			3/8-5/8	5/16	.312	4	.81	2.5	T-CT24UN-335C	\$188.10
20	1/4			1/4	.185	3	.48	2.5	T-CT20UN-340C	\$168.30
20		7/16		5/16	.312	3	.83	2.5	T-CT20UN-345C	\$188.10
20		1/2		3/8	.375	4	.88	3.0	T-CT20UN-350C	\$198.00
20			3/4-1	1/2	.500	5	1.07	4.0	T-CT20UN-355C	\$217.80
18	5/16			1/4	.220	3	.58	2.5	T-CT18UN-360C	\$168.30
18		9/16-5/8	11/8-15/8	1/2	.445	4	1.03	4.0	T-CT18UN-365C	\$217.80
16	3/8			5/16	.264	3	.66	2.5	T-CT16UN-370C	\$188.10
16		3/4		1/2	.500	4	1.22	4.0	T-CT16UN-375C	\$217.80
14	7/16			5/16	.303	3	.82	2.5	T-CT14UN-380C	\$188.10
14		7/8		5/8	.625	5	1.46	4.0	T-CT14UN-385C	\$297.00
13	1/2			3/8	.362	3	.89	3.0	T-CT13UN-390C	\$198.00
12	9/16			1/2	.413	3	1.04	4.0	T-CT12UN-395C	\$217.80
12		1-11/2		5/8	.625	5	1.63	4.0	T-CT12UN-400C	\$297.00
11	5/8			1/2	.449	3	1.14	4.0	T-CT11UN-405C	\$217.80
10	3/4			5/8	.567	4	1.35	4.0	T-CT10UN-410C	\$297.00
9	7/8			5/8	.625	3	1.50	4.0	T-CT9UN-415C	\$297.00

SOLID CARBIDE THREADMILLS NPT

Full Line Available!
Please call for more information.

Carmex
Precision Tools Ltd.

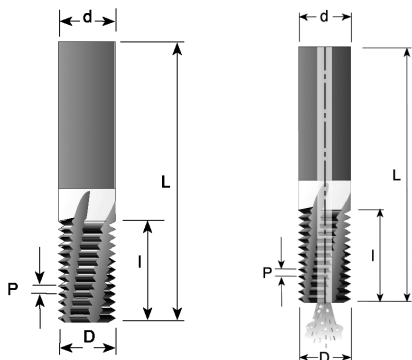

TPI	Standard	d	D	No. Of Flutes	I	L	Part Number	Price Each
NO COOLANT PASSAGE								
27	1/8	1/4	.250	3	.39	2.5	T-CT27NPT-100	\$168.30
18	1/4-3/8	5/16	.312	3	.58	2.5	T-CT18NPT-105	\$188.10
14	1/2-3/4	1/2	.500	4	.82	3.0	T-CT14NPT-110	\$217.80
11.5	1-2	5/8	.625	4	1.09	4.0	T-CT115NPT-115	\$297.00
8	>21/2	3/4	.750	4	1.56	4.0	T-CT8NPT-120	\$405.90
With Thru Coolant Hole								
27	1/8	5/16	.299	3	.43	2.5	T-CT27NPT-125C	\$188.10
18	1/4-3/8	3/8	.375	4	.64	3.0	T-CT18NPT-130C	\$198.00
14	1/2-3/4	5/8	.610	4	.89	4.0	T-CT14NPT-135C	\$297.00
11.5	1-2	3/4	.750	4	1.17	4.0	T-CT115NPT-140C	\$405.90

Call Us Today For All Of Your Machine Tool Needs!

SOLID CARBIDE THREADMILLS DRYSEAL

Free Programming Help!
Please Call For More Information.

Carmex
Precision Tools Ltd.

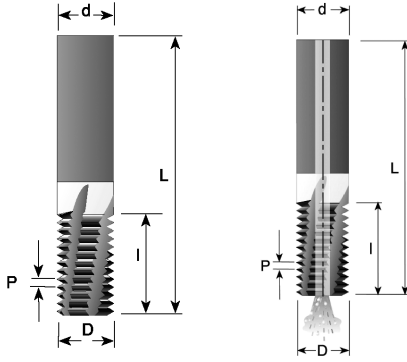

TPI	Standard	d	D	No. Of Flutes	I	L	Part Number	Price Each
No Coolant Passage								
27	1/8	1/4	.250	3	0.39	2.5	T-CT27NPTF-145	\$168.30
18	1/4-3/8	5/16	.312	3	0.58	2.5	T-CT18NPTF-150	\$188.10
14	1/2-3/4	1/2	.500	4	0.82	3.0	T-CT14NPTF-155	\$217.80
11.5	1-2	5/8	.625	4	1.09	4.0	T-CT115NPTF-160	\$297.00
8	>2 1/2	3/4	.750	4	1.56	4.0	T-CT8NPTF-165	\$405.90
With Thru Coolant Hole								
27	1/8	5/16	.299	3	0.43	2.5	T-CT27NPTF-170C	\$188.10
18	1/4-3/8	3/8	.375	4	0.64	3.0	T-CT18NPTF-175C	\$198.00
14	1/2-3/4	5/8	.610	4	0.89	4.0	T-CT14NPTF-180C	\$297.00
11.5	1-2	3/4	.750	4	1.17	4.0	T-CT115NPTF-185C	\$405.90

SOLID CARBIDE THREADMILLS ISO METRIC 360°

Carmex
Precision Tools Ltd.

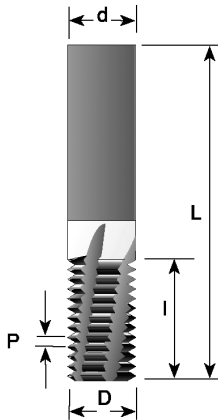

Full Line Available!
Please call for more information.

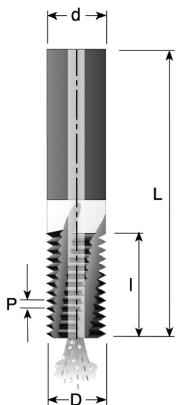

Pitch mm	Metric Coarse	Metric Fine	d	D	No. of flutes	I	L	Part Number	Price Each
No Coolant Passage									
0.5	M3	ø>=.16	1/4	.087	3	.21	2.5	T-CT0.5M-500	\$168.30
0.5	-	ø>=.20	1/4	.150	3	.41	2.5	T-CT0.5M-505	\$168.30
0.7	M4	ø>=.20	1/4	.122	3	.29	2.5	T-CT0.7M-510	\$168.30
0.75	-	ø>=.24	1/4	.177	3	.40	2.5	T-CT0.75M-515	\$168.30
0.8	M5	ø>=.24	1/4	.142	3	.36	2.5	T-CT0.8M-520	\$168.30
1.0	M6	ø>=.28	1/4	.157	3	.41	2.5	T-CT1.0M-525	\$168.30
1.0	M6	ø>=.28	1/4	.157	3	.57	2.5	T-CT1.0M-530	\$168.30
1.0	-	ø>=.35	1/4	.236	3	.49	2.5	T-CT1.0M-535	\$168.30
1.0	-	ø>=.39	5/16	.313	4	.65	2.5	T-CT1.0M-540	\$188.10
1.25	M8	ø>=.39	1/4	.197	3	.57	2.5	T-CT1.25M-545	\$168.30
1.25	M8	ø>=.39	1/4	.197	3	.76	2.5	T-CT1.25M-550	\$168.30
1.5	M10	ø>=.47	5/16	.276	3	.68	2.5	T-CT1.5M-555	\$188.10
1.5	M10	ø>=.47	5/16	.276	3	.98	2.5	T-CT1.5M-560	\$188.10
1.5	-	ø>=.55	3/8	.375	4	.86	3.0	T-CT1.5M-565	\$198.00
1.5	-	ø>=.79	5/8	.625	6	1.33	4.0	T-CT1.5M-570	\$297.00
1.75	M12	ø>=.55	5/16	.313	3	.79	2.5	T-CT1.75M-575	\$188.10
1.75	M12	ø>=.55	5/16	.313	3	1.14	2.5	T-CT1.75M-580	\$188.10
2.0	M16	ø>=.67	3/8	.375	3	1.06	3.0	T-CT2.0M-585	\$198.00
2.0	M16	ø>=.67	3/8	.375	3	1.54	3.0	T-CT2.0M-590	\$198.00
2.0	-	ø>=.71	1/2	.472	4	1.06	3.0	T-CT2.0M-595	\$217.80
2.0	-	ø>=1.02	3/4	.750	6	1.61	4.0	T-CT2.0M-600	\$405.90
2.5	M20	ø>=.87	5/8	.551	4	1.33	4.0	T-CT2.5M-605	\$297.00
2.5	M20	ø>=.87	5/8	.551	4	1.92	4.0	T-CT2.5M-610	\$297.00
3.0	M24	ø>=.98	5/8	.625	3	1.59	4.0	T-CT3.0M-615	\$297.00
3.0	M24	ø>=.98	5/8	.625	3	2.31	4.0	T-CT3.0M-620	\$297.00
3.0	M28	ø>=1.10	3/4	.750	4	1.71	4.0	T-CT3.0M-625	\$405.90
With Thru Coolant Hole									
0.5	-	ø>=.20	1/4	.150	3	.41	2.5	T-CT0.5M-630C	\$168.30
0.7	M4	ø>=.20	1/4	.122	3	.29	2.5	T-CT0.7M-635C	\$168.30
0.75	-	ø>=.24	1/4	.177	3	.40	2.5	T-CT0.75M-640C	\$168.30
0.8	M5	ø>=.24	1/4	.150	3	.36	2.5	T-CT0.8M-645C	\$168.30
1.0	M6	ø>=.28	1/4	.181	3	.41	2.5	T-CT1.0M-650C	\$168.30
1.0	M6	ø>=.28	1/4	.181	3	.60	2.5	T-CT1.0M-655C	\$168.30
1.0	-	ø>=.35	1/4	.250	3	.50	2.5	T-CT1.0M-660C	\$168.30
1.0	-	ø>=.39	5/16	.312	4	.65	2.5	T-CT1.0M-665C	\$188.10
1.25	M8	ø>=.39	1/4	.250	3	.57	2.5	T-CT1.25M-670C	\$168.30
1.25	M8	ø>=.39	1/4	.250	3	.76	2.5	T-CT1.25M-675C	\$168.30
1.5	M10	ø>=.47	5/16	.307	3	.67	2.5	T-CT1.5M-680C	\$188.10
1.5	M10	ø>=.47	5/16	.307	3	.98	2.5	T-CT1.5M-685C	\$188.10
1.5	-	ø>=.55	3/8	.375	4	.86	3.0	T-CT1.5M-690C	\$198.00
1.5	-	ø>=.79	5/8	.625	6	1.33	4.0	T-CT1.5M-695C	\$297.00
1.75	M12	ø>=.47	3/8	.354	3	.79	3.0	T-CT1.75M-700C	\$198.00
1.75	M12	ø>=.47	3/8	.354	3	1.14	3.0	T-CT1.75M-705C	\$198.00
2.0	M14	ø>=.59	3/8	.375	3	1.06	3.0	T-CT2.0M-710C	\$198.00
2.0	M16	ø>=.67	1/2	.465	4	1.06	4.0	T-CT2.0M-715C	\$217.80
2.0	M16	ø>=.67	1/2	.465	4	1.54	4.0	T-CT2.0M-720C	\$217.80
2.0	-	ø>=.94	3/4	.750	6	1.61	4.0	T-CT2.0M-725C	\$405.90

Call Us Or Visit Our Website For Our Complete Selection!

LATHE CHUCKS
LIVE CENTERS
VISE JAWS
VISE ACCESSORIES
STRAIGHT SHANK
COLLET HOLDERS
TAP HOLDERS
DRILL CHUCKS
CARBIDE INSERTS
THREADING/GROOVING
CUTTING TOOLS
MACHINERY
PRECISION TOOLS
DEBURRING
COOLANT/FLUIDS
TOOL STORAGE

THREADMILLS

HELICAL FLUTE THREAD MILLS UN, NPT & NPTF THREADS SOLID CARBIDE-AITiN Coated

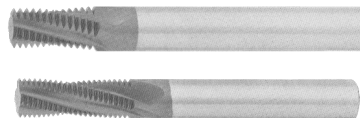

FEATURES:

- Completely CNC ground
- Helical flute design for reduced cutting forces, smoother cuts, longest tool life and maximum thread milling performance
- 100% thread form for superior threads compared to tapping
- Cuts right and left hand threads
- Suitable for all types of materials, including heat treated and difficult to machine workpieces.
- Supplied with AITiN coating. Uncoated thread mills also available, please call for more information

HELICAL FLUTE THREAD MILLS- NPT, NPTF THREADS

Minimum Thread	Pitch	Cut. Dia D1	Shank Dia D2	OAL L1	LOC L2	No. Of Flutes	Part Number	Price Each
1/16 & 1/8 NPT	27	.245	1/4	2-1/2	0.437	3	MI-TM27NPTX	\$200.40
1/4 & 3/8 NPT	18	.305	5/16	2-1/2	0.625	4	MI-TM18NPTX	\$215.10
1/2 & 3/4 NPT	14	.495	1/2	4	0.875	4	MI-TM14NPTX	\$236.25
1" & 2" NPT	11.5	.620	5/8	4	1.125	4	MI-TM11NPTX	\$310.80
1/16 & 1/8 NPTF	27	.245	1/4	2-1/2	0.437	3	MI-TM27NPTFX	\$212.85
1/4 & 3/8 NPTF	18	.305	5/16	2-1/2	0.625	4	MI-TM18NPTFX	\$242.90
1/2 & 3/4 NPTF	14	.495	1/2	4	0.875	4	MI-TM14NPTFX	\$269.25
1" & 2" NPTF	11.5	.620	5/8	4	1.125	4	MI-TM11NPTFX	\$353.80

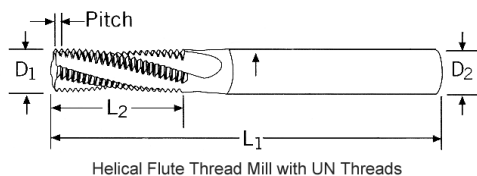
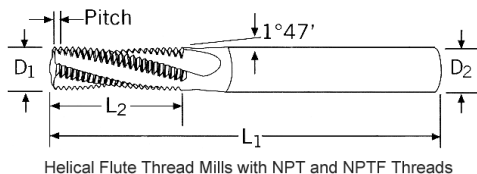

Full Line Available!
Please call for more information.

Shank Diameter	-.0001 to -.0003"
Cutter Diameter	± .0005"
Length of Cut	+.050 to .000"
Overall Length	± .015"
T.I.R. Maximum	.0005"

HELICAL FLUTE THREAD MILLS- UN THREADS

Minimum Thread & Pitch	Cut. Dia D1	Shank Dia D2	OAL L1	LOC L2	No. Of Flutes	Part Number	Price Each
4-40	.080	1/4	2	3/16	2	MI-TM11240X	\$155.75
6-32	.100	1/4	2	1/4	2	MI-TM13832X	\$155.75
8-32	.115	1/4	2	1/4	3	MI-TM16432X	\$155.75
10-24	.120	1/4	2	5/16	3	MI-TM19024X	\$163.20
10-28	.120	1/4	2	5/16	3	MI-TM19028X	\$163.20
10-32	.120	1/4	2	5/16	3	MI-TM19032X	\$163.20
1/4-20	.180	1/4	2-1/2	1/2	3	MI-TM25020X	\$171.75
1/4-28	.180	1/4	2-1/2	1/2	3	MI-TM25028X	\$171.75
5/16-18	.235	1/4	2-1/2	5/8	3	MI-TM31218X	\$187.40
5/16-24	.235	1/4	2-1/2	5/8	3	MI-TM31224X	\$187.40
3/8-16	.285	5/16	2-1/2	3/4	4	MI-TM37516X	\$227.85
3/8-24	.285	5/16	2-1/2	3/4	4	MI-TM37524X	\$227.85
7/16-14	.305	5/16	2-1/2	3/4	4	MI-TM43714X	\$227.85
7/16-20	.335	3/8	3	7/8	4	MI-TM43720X	\$238.95
1/2-13	.350	3/8	3	7/8	4	MI-TM50013X	\$238.95
9/16-12	.370	3/8	3	7/8	4	MI-TM5622X	\$238.95
9/16-18	.370	3/8	3	7/8	4	MI-TM56218X	\$238.95
5/8-11	.470	1/2	4	1-1/4	4	MI-TM62511X	\$278.00
3/4-10	.495	1/2	4	1-1/4	4	MI-TM75010X	\$278.00
3/4-12	.495	1/2	4	1-1/4	4	MI-TM75012X	\$278.00
3/4-16	.495	1/2	4	1-1/4	4	MI-TM75016X	\$278.00
7/8-9	.620	5/8	4	1-3/8	4	MI-TM87509X	\$300.00
7/8-14	.490	1/2	4	1-1/4	4	MI-TM87514X	\$278.00
1"-8	.620	5/8	4	1-3/8	4	MI-TM00108X	\$300.00

SOLID CARBIDE MINI THREADMILLS UN-UNIFIED AMERICAN 60° General Purpose For All Materials

Free Programming Help!
Please Call For More Information.

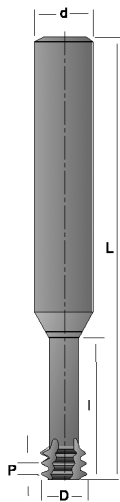

TPI	UNC	UNF	d	D	No of Flutes	I	L	Part Number	Price Each
-----	-----	-----	---	---	--------------	---	---	-------------	------------

For Thread Depth Up To 2xD

72	-	1	1/4	.057	3	.15	2.5	T-CMTS72UN-800	\$126.00
64	1	2	1/4	.055	3	.15	2.5	T-CMTS64UN-805	\$138.60
56	2	3	1/4	.065	3	.17	2.5	T-CMTS56UN-810	\$138.60
48	3	4	1/4	.075	3	.20	2.5	T-CMTS48UN-815	\$138.60
40	4	-	1/4	.083	3	.25	2.5	T-CMTS40UN-820	\$138.60
40	5	6	1/4	.096	3	.28	2.5	T-CMTS40UN-825	\$138.60
36	-	8	1/4	.130	3	.35	2.5	T-CMTS36UN-830	\$138.60
32	6	-	1/4	.100	3	.28	2.5	T-CMTS32UN-835	\$138.60
32	8	10	1/4	.126	3	.37	2.5	T-CMTS32UN-840	\$138.60
28	-	1/4	1/4	.197	3	.57	2.5	T-CMTS28UN-845	\$138.60
24	10, 12	-	1/4	.138	3	.42	2.5	T-CMTS24UN-850	\$138.60
24	-	5/16	5/16	.260	3	.67	2.5	T-CMTS24UN-855	\$148.50
20	1/4	-	1/4	.187	3	.55	2.5	T-CMTS20UN-860	\$138.60

For Thread Depth Up To 3xD

40	5	6	1/4	.096	3	.38	2.5	T-CMTS40UN-865	\$138.60
32	8	10	1/4	.126	3	.49	2.5	T-CMTS32UN-870	\$138.60
28	-	1/4	1/4	.197	3	.75	2.5	T-CMTS28UN-875	\$138.60
24	-	5/16	5/16	.260	3	.94	2.5	T-CMTS24UN-880	\$148.50
20	1/4	-	1/4	.187	3	.75	2.5	T-CMTS20UN-885	\$138.60

Call Us Today For All Of Your Machine Tool Needs!