

## WHY BUY A COLLET CHUCK?

Collet chucks can be easily installed on almost any CNC lathe, whether it is new or old. They can be interchanged with 3 jaw chucks or installed permanently, depending on the jobs required. Here are some other advantages of a collet chuck:

- Gripping force is spread over the entire circumference of the workpiece instead of being concentrated at just three points.
- Jobs can be run at higher RPMs because collet chucks are not as vulnerable to the negative effects of centrifugal force.
- Collet chucks offer better tool clearance and easier access to workpiece.
- Collet changeover time is usually faster than changing chuck jaws.
- No boring of jaws is required.
- Collet chucks usually have much less mass than 3 jaw chucks, reducing wear on machine tool spindle bearings and allowing for quicker starts and stops.
- Collets are readily available.

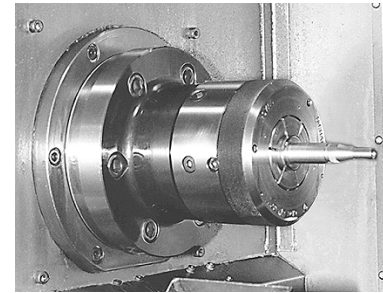

### Collet Chuck Applications:

Bar feeding/Bar pulling • Slug work • Small diameter work less than 3"  
Twin or subspindle machines • Delicate thin-walled parts  
High RPM applications • Parts that require extra tool clearance for machining

## CNC PULLBACK COLLET CHUCKS

For 5C, 16C & 3J Collets

### FEATURES:

- A simple, low-cost method for utilizing collets on all CNC lathes and turning centers.
- Pullback design.
- 0.0003" TIR guaranteed.
- Body hardened to Rc61-63 for rigidity
- Accepts 5C, 16C & 3J collets and tooling.

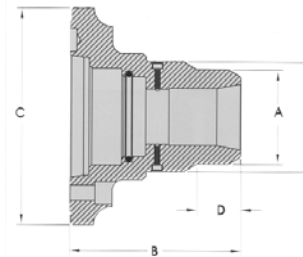

Collet Type	Spindle	Cap.	Threaded Nose	A	B	C	D	E	Max Drawbar Force (lbs.)	Max Clamping Force (lbs.)	Max RPM	Part Number	Price
5C	A2-5	1-1/16	N	2.63	5.00	6.45	1.05	3.14	4,490	15,750	6,000	ROY-42053	\$1,166.20
	A2-5	1-1/16	Y	2.187-10	5.00	6.45	1.22	3.14	4,490	15,750	6,000	ROY-42054	\$1,303.40
	A2-6	1-1/16	N	2.63	5.00	7.45	1.05	3.14	4,490	15,750	6,000	ROY-42055	\$1,372.00
	A2-6	1-1/16	N	2.63	6.00	7.45	1.05	3.14	4,490	15,750	6,000	ROY-42057	\$1,528.80
	A2-6	1-1/16	Y	2.187-10	6.00	7.45	1.22	3.14	4,490	15,750	6,000	ROY-42058	\$1,646.40
	A2-8	1-1/16	N	2.63	6.00	9.45	1.05	3.14	4,490	15,750	4,500	ROY-42059	\$1,685.60
16C	A2-5	1-5/8	N	3.00	6.00	6.45	1.85	3.31	5,390	19,800	6,000	ROY-42067	\$1,450.40
	A2-6	1-5/8	N	3.25	6.00	7.45	1.54	3.78	5,390	19,800	6,000	ROY-42069	\$1,528.80
	A2-8	1-5/8	N	3.25	6.00	9.45	1.54	3.78	5,390	19,800	4,500	ROY-42071	\$1,675.80
3J	A2-5	1-3/4	N	3.08	6.00	6.45	1.16	3.33	5,390	19,800	6,000	ROY-42061	\$1,489.60
	A2-6	1-3/4	N	3.25	6.00	7.45	1.05	3.87	5,390	19,800	6,000	ROY-42063	\$1,617.00

## CNC ACCU-LENGTH COLLET CHUCKS

For 5C, 16C & 3J Collets

### FEATURES:

- Exclusive Accu-Length™ system eliminates part pullback.
- Guaranteed max. closing sleeve runout relative to mounting recess is 0.00025".
- Patented floating collet retainer improves concentricity.
- Accepts all standard 5C and 16C accessories & tooling.
- Ideal for sub-spindle applications.
- Collet wrench and oiler included with chuck.

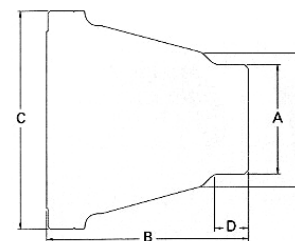

Collet Type	Spindle Type	Cap.	A	B	C	D	E	Max Drawbar Force (lbs)	Max Clamping Force (lbs)	Max RPM	Part Number	Price
5C	A2-5	1-1/16"	2.43	5.75	6.45	1.00	4.00	4,000	13,600	6,000	ROY-42330	\$4,037.60
	A2-6	1-1/16"	2.43	5.75	7.45	1.00	4.00	4,000	13,600	6,000	ROY-42332	\$4,223.80
16C	A2-5	1-5/8"	3.25	6.25	6.45	1.03	3.90	5,400	18,300	6,000	ROY-42338	\$4,419.80
	A2-6	1-5/8"	3.25	7.00	7.95	1.03	4.48	5,400	18,300	6,000	ROY-42340	\$4,576.60
	A2-8	1-5/8"	3.25	7.75	9.45	1.03	4.48	5,400	18,300	4,500	ROY-42342	\$4,713.80
3J	A2-5	1-3/4"	3.25	6.00	6.45	1.03	3.97	5,400	26,300	6,000	ROY-42344	\$4,576.60
	A2-6	1-3/4"	3.25	6.50	7.95	1.03	4.48	5,400	26,300	6,000	ROY-42346	\$4,713.80
	A2-8	1-3/4"	3.25	7.25	9.45	1.03	4.48	5,400	26,300	4,500	ROY-42348	\$4,880.40

Call Us Or Visit Our Website For Our Complete Selection!

# COLLET CHUCKS

## CNC PULLBACK COLLET CHUCKS For 16C, 3J & 5C Collets



- 5C collets readily available.
- 16C collet chucks are popular due to their capacity (1.625").
- 5C and 16C systems available with step chuck capability.
- Step chuck capacities range from 2" to 6" in diameter.

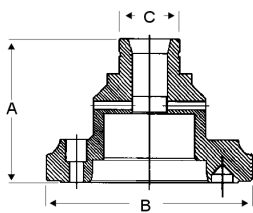

**WARNING:** Do not use manual jaw chucks, fixture mounting plates or face plates on ATS 5C threaded nose. Cast iron step chuck closers are not recommended for speeds greater than 4000 RPM or draw bar forces over 5,000 lbs.

Description	Spindle	OAL A	B	C	Cap.	Part Number	Price
-------------	---------	-------	---	---	------	-------------	-------

### 16C (Utilizes standard 16C collets)

A5-16C	A2-5	6.250	6.450	3.400	1.625	ATS-1650-B05	\$1,390.00
A6-16C	A2-6	6.250	7.450	4.000	1.625	ATS-1660A-D01	\$1,490.00
A8-16C	A2-8	6.500	9.450	5.375	1.625	ATS-1680A-A17	\$1,590.00

### 5C (Utilizes standard 5C collets)

A5-5CB	A2-5	5.000	6.450	2.180	1.062	ATS-5050-B01	\$1,290.00
A5-5CA	A2-5	3.500	6.450	2.180	1.062	ATS-5050-B03	\$1,290.00
A6-5C1	A2-6	5.000 (1)	7.450	2.250	1.062	ATS-5060A-A05	\$1,290.00
A6-5CA	A2-6	5.000	7.450	2.180	1.062	ATS-5060A-C01	\$1,390.00
AB-5C1	A2-8	6.000 (1)	9.450	2.250	1.062	ATS-5080A-A14	\$1,490.00
AB-5C	A2-8	6.000	9.450	2.180	1.062	ATS-5080A-A13	\$1,590.00

### 3J (Utilizes standard 3J collets)

A5-3J	A2-5	5.750	6.450	3.400	1.750	ATS-3050-B07	\$1,390.00
A6-3J	A2-6	6.000	7.450	4.000	1.750	ATS-3060A-D03	\$1,490.00
A8-3J	A2-8	6.000	9.450	5.370	1.750	ATS-3080A-F17	\$1,790.00

(1) - Non Threaded Nose S/C - Step Chuck Capability

## LOW PROFILE TRUE LENGTH COLLET CHUCKS For 5C, 16C & 3J Collets



- Adjustable feature for T.I.R. and concentricity.
- Fixed collet position increases linear precision.
- Ideal for secondary operations, sub-spindle applications and part transfers.
- Small body design provides for greater tool clearance, Z-axis travel and rigidity.

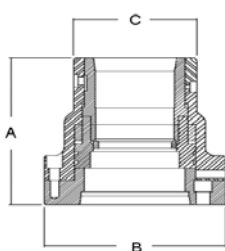

Description	Spindle	OAL A	B	C	Cap.	Part Number	Price
-------------	---------	-------	---	---	------	-------------	-------

### 5C (Utilizes standard 5C collets)

750AG05-50 A5-5CTL	A2-5	5.740	6.450	2.500	1.062	ATS-750AG0550	\$3,630.50
750AG5-60 A6-5CTL	A2-6	5.750	7.450	2.500	1.062	ATS-750AG560	\$3,990.00
750AG05-80 A8-5CTL	A2-8	7.000	8.450	2.500	1.062	ATS-750AG0580	\$4,090.00

### 16C (Utilizes standard 16C collets)

716AK40-60 A6-16CTL	A6	7.000	7.000	3.250	1.625	ATS-716AK4060	\$4,290.00
716AK40-80 A8-16CTL	A8	7.750	8.450	3.250	1.625	ATS-716AK4080	\$4,390.00

### 3J (Utilizes standard 3J collets)

730AH05-60 A6-3JTL	A2-6	6.500	7.000	3.250	1.750	ATS-730AH0560	\$4,390.00
730AH05-80 A8-3JTL	A2-8	7.250	8.450	3.250	1.750	ATS-730AH0580	\$4,590.00

## CNC PULLBACK COLLET CHUCKS For "S" Style Collets



- "S" style is common in automatic screw and turret type machines.
- Utilizes standard "S" style collet pads-see page 64.

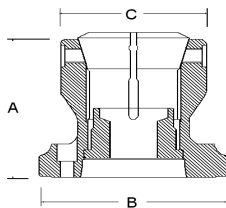

Collet Series	Spindle	OAL		Flange		Nose		Cap.	Part Number	Price
		A	B	B	C	C	C			
S-20	A2-6	5.575	7.450	7.450	4.400	2.000	2.000	ATS-42060A-D05	\$3,390.00	
S-20	A2-6	6.750	7.450	7.450	4.400	2.000	2.000	ATS-42060A-D07	\$3,390.00	
S-22	A2-6	7.250	7.450	7.450	5.000	2.250	2.250	ATS-42260-E06	\$3,590.00	
S-26	A2-6	5.750	7.450	7.450	5.750	2.625	2.625	ATS-42660B-E03	\$3,690.00	
S-26	A2-8	7.000	9.450	9.450	5.750	2.625	2.625	ATS-42680B-D16	\$3,690.00	
S-30	A2-6	6.375	7.450	7.450	5.750	3.000	3.000	ATS-43060-E08	\$4,090.00	
S-30	A2-8	6.525	9.450	9.450	5.750	3.000	3.000	ATS-43080A-E15	\$4,090.00	
S-30	A2-8	7.675	9.450	9.450	5.750	3.000	3.000	ATS-43080A-K05	\$4,190.00	

H - Hardinge HS - Hardinge (Short)

## UNIVERSAL COLLET ADAPTER 16C, 3J & 2J to 5C Adapters

Allows you to use 5C collets on your 16C, 3J or 2J Chucks!

- Available to adapt 5C collets for use in 16C, 3J & 2J collet chucks
- Manufactured from 1144 Steel
- TIR 0.0005
- Made in the USA

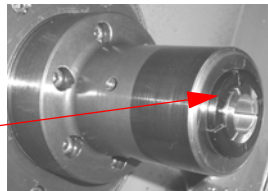

Description	Part Number	Price
16C to 5C Adapter	VIC-16CTO5C	\$219.00
3J to 5C Adapter	VIC-3JTO5C	
2J to 5C Adapter	VIC-2JTO5C	

D

Call Us Today For All Of Your Machine Tool Needs!

# "S" STYLE COLLET CHUCKS

TABLE OF CONTENTS

## CNC PULLBACK COLLET CHUCKS

### For S-Style Collets

- Simply change collet pads to hold different part diameters
- Collet pads also available-see pages 64
- S-Type collet chucks include master collet, wrench, mounting hardware and custom-machined drawtube adapter

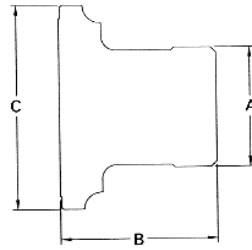

Collet Type	Spindle	Cap.	A	B	C	Chuck Weight	Max Drawbar Force (Lbs.)	Max Gripping Force(Lbs.)	Max RPM	Part Number	Price
S-20 Master	A2-6	2"	4.40	5.57	7.45	17 lbs	6,000	14,700	6,000	ROY-45110	\$3,596.60
S-26 Master	A2-6	2-5/8"	5.75	6.25	7.45	21 lbs	6,500	15,925	6,000	ROY-45112	\$3,861.20
S-26 Master	A2-8	2-5/8"	5.75	6.25	9.45	42 lbs	6,500	15,925	4,500	ROY-45114	\$4,018.00
S-30 Master	A2-8	3"	5.75	6.53	9.45	53 lbs	7,000	17,150	4,500	ROY-45116	\$4,165.00

## CNC ACCU-LENGTH COLLET CHUCKS

### For "S" Style Collets

- Exclusive Accu-Length™ system eliminates part pullback
- Guaranteed max. closing sleeve runout relative to mounting recess is 0.00025"
- Patented floating collet retainer improves concentricity.
- Ideal for sub-spindle applications
- Collet wrench and oiler included with chuck
- Master collet included on S-Type collet chucks

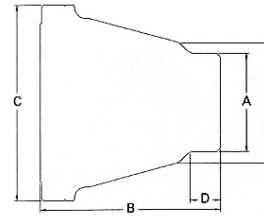

Collet Type	Spindle Type	Capacity	A	B	C	D	E	Max Drawbar Force (lbs)	Max Clamping Force (lbs)	Max RPM	Part Number	Price
S-20	A2-5	2"	4.81	6.38	7.95	1.30	6.25	6,000	29,300	6,000	ROY-42360	\$5,076.40
	A2-6	2"	4.81	6.75	7.95	1.30	6.25	6,000	29,300	6,000	ROY-42362	\$5,448.80
S-26	A2-6	2-5/8"	5.50	7.00	7.95	1.50	6.75	8,000	39,100	6,000	ROY-42364	\$5,595.80
S-30	A2-6	3"	6.06	6.62	7.95	1.50	6.75	10,000	48,800	6,000	ROY-42368	\$6,095.60
	A2-8	3"	6.06	6.62	9.45	1.50	6.75	10,000	48,800	4,500	ROY-42370	\$6,095.60

## MASTER JAW COLLET SYSTEM

### Use 5C Or 16C Collets On Your 3 Jaw Chuck



Convert Your CNC Lathe Chuck Into A Precision-Length Collet System!



The Master Jaw System is available for 6, 8, 10 and 12 inch CNC power chucks. A cost effective and efficient alternative to a standard collet chuck that eliminates the need to remove your chuck from the machine. This system provides a positive stop-dead length for repeatable part lengths. Installation is as fast and easy as installing a set of soft jaws. The ability to go from working with standard jaws to running collets in just minutes will sky rocket your shop's productivity. A TIR runout average of .0008 - .0015 in. can be expected above your collet's factory tolerances and is dependent on the condition of your chuck and the quality of your collets. This amazing system is completely made in the USA from high grade materials. The collet housing is made from US heat treated 4140 alloy steel and the jaws are US 1018 CR steel that can be case hardened. The system comes with a black oxide finish.

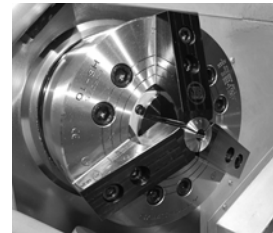

- Available for 6", 8", 10" & 12" CNC lathe chucks
- Allows you to use your 5C or 16C collets
- Easy Installation! As fast and simple as changing over a set of soft jaws
- Quick changeover to different stock sizes & shapes
- Eliminates the need to bore soft jaws
- TIR runout average of .0008 - .0015"
- Saves you time and money!
- **MADE IN THE USA**

#### MASTER JAW SYSTEM

##### Includes:

- 1 set of 3 master jaws
- 1 collet sleeve
- 1 anti-backlash plug
- Setup instructions

Fits Chuck Make/Model	Chuck Size	Serrations	Groove Width	Hole Spacing	Chuck Thru-Hole	Part Number	Price Each
-----------------------	------------	------------	--------------	--------------	-----------------	-------------	------------

#### For 5C Collets

Kitagawa B206, Strong N206,	6"	1.5mm x 60°	0.472	0.787	45mm	ED-MJSK6LA	\$783.75
Samchully HS06	6"		0.472	0.787	46mm	ED-MJSK6HA	\$783.75
Kitagawa B208, Strong N208, Samchully HS08	8"		0.551	0.984	52mm	ED-MJSK8LA	\$783.75
Kitagawa B210, Strong N210	10"		0.630	1.181	75mm	ED-MJSK10LA	\$783.75
Samchully HS10	10"		0.630	1.181	77mm	ED-MJSK10HA	\$783.75
Kit B212, Strong N212, Samchully HS12	12"		0.827	1.181	91mm	ED-MJSK12LA	\$855.00

#### For 16C Collets

Kitagawa BB206	6"	1.5mm x 60°	0.472	0.787	53mm	ED-MJSK6B-16	\$12.25
Kitagawa B208, Strong N208, Samchully HS08	8"		0.551	0.984	52mm	ED-MJSK8LA-16	\$812.25
Kitagawa B210, Strong N210	10"		0.630	1.181	75mm	ED-MJSK10LA-16	\$812.25
Samchully HS10	10"		0.630	1.181	77mm	ED-MJSK10HA-16	\$812.25

\*Additional systems available, allow 7-10 working days to manufacture. Please call for more information.

Call Us Or Visit Our Website For Our Complete Selection!

2019-20 MASTER CATALOG

89

LATHE CHUCKS  
LIVE CENTERS

VICE JAWS  
VICE ACCESSORIES

STRAIGHT SHANK  
COLLET HOLDERS

TAP HOLDERS  
DRILL CHUCKS

CARBIDE INSERTS  
THREADING/GROOVING

CUTTING TOOLS  
MACHINERY

PRECISION TOOLS  
DEBURRING

COOLANT/FLUIDS  
TOOL STORAGE

# QUICK-GRIP™ COLLET CHUCKS



## QUICK-GRIP™ COLLET CHUCKS

### 10-SECOND COLLET CHANGES!

- **10-Second Collet Changes!** A unique hook and groove design for securing collets is used instead of traditional threads
- **Widest Collet Gripping Range!** Royal Quick-Grip™ collets have a .062" gripping range (+/-0.031"), allowing them to accommodate undersized and oversized bar stock
- **Ultra-Compact Design-**Quick-grip™ CNC collet chucks have smaller nose diameters than other quick-change collet chucks for superior tool clearance
- Royal Quick-Grip™ collet chucks are balanced by design for high-speed operation, and can often be run at higher speeds than conventional 3-jaw chucks because they are less affected by centrifugal force
- **Extremely Accurate-**Runout on the closing angle is guaranteed to be within 0.0002" TIR
- Quick-Grip™ collet chucks can also utilize MicroCentric™ and Hainbuch™ Quick-change collets
- Available in Accu-Length or Pullback styles
- **Made in the USA**



### Exclusive "Bolt & Go" Mounting Advantage On All Royal Collet Chucks!

Many Royal chuck models mount directly to the lathe spindle without the need for an adapter plate. However, for models that do use a plate, a precision-ground tapered fit between the plate's male pilot and chuck body's female recess ensures a consistent, near-perfect fit without the need for any adjustment. Knock 30 minutes off your setup time with Royal bolt & Go™!

## QUICK-GRIP™ ACCU-LENGTH™ CNC COLLET CHUCKS

Royal Accu-Length™ CNC collet chucks incorporate dead-length operation to eliminate part pullback. With this design, a tapered sleeve pushes forward over the collet to compress it, resulting in precise z-axis positioning.

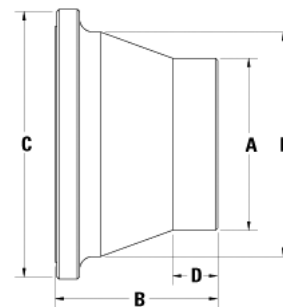

Spindle Type	Collet Series	Cap.	A	B	C	D	E	Chuck Weight	Max. Drawbar Force	Max Clamping Force	Max RPM	Part Number	Price
A2-5	QG-42	1-5/8	3.86	4.60	6.45	0.98	5.70	15	7,865	14,160	6,000	ROY-44055	\$3,260.00
A2-6	QG-42	1-5/8	3.86	4.45	7.25	0.98	6.20	17	7,865	14,160	6,000	ROY-44053	\$3,260.00
A2-5	QG-65	2-5/8	4.69	4.80	7.25	1.00	6.45	19	10,115	23,600	6,000	ROY-44065	\$3,680.00
A2-6	QG-65	2-5/8	4.69	5.33	7.25	1.00	6.45	23	10,115	23,600	6,000	ROY-44067	\$3,680.00
A2-8	QG-65	2-5/8	4.69	5.50	9.45	1.00	8.00	37	10,115	23,600	6,000	ROY-44068	\$4,160.00

## QUICK-GRIP™ PULL-TO-A-STOP CNC COLLET CHUCKS

Royal Pullback CNC collet chucks provide a simple, low-cost method for utilizing Quick-Grip™ collets on all CNC lathes and turning centers

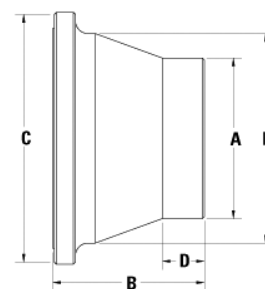

- Traditional pullback design-collet is pulled into chuck to close, pushed out to open
- No collet stop capability-**this chuck style is typically used only on jobs where holding precise axial position is not critical**
- 0.0002" TIR accuracy on closing angle
- Compact dimensions for superior clearance

Spindle Type	Collet Series	Cap.	A	B	C	D	E	Chuck Weight	Max. Drawbar Force	Max Clamping Force	Max RPM	Part Number	Price
A2-5	QG-42	1-5/8	4.11	4.45	6.45	3.50	5.25	11	7,865	14,160	6,000	ROY-44020	\$1,999.20
A2-6	QG-42	1-5/8	4.11	4.35	7.45	1.50	4.38	13	7,865	14,160	6,000	ROY-44022	\$2,146.20
A2-5	QG-65	2-5/8	4.88	4.30	6.45	1.50	6.45	19	10,115	18,205	6,000	ROY-44028	\$2,273.60
A2-6	QG-65	2-5/8	4.88	4.85	7.45	1.50	5.25	17	10,115	18,205	6,000	ROY-44030	\$2,273.60
A2-8	QG-65	2-5/8	4.88	5.00	9.45	1.50	5.72	26	10,115	18,205	6,000	ROY-44032	\$2,812.60

Please See Following Page For Quick-Grip™ Collets And Accessories

Call Us Today For All Of Your Machine Tool Needs!



## QUICK-GRIP™ COLLETS

- For use with Royal Quick-Grip™ Collet Chucks
- Precision ground to nominal size, with a gripping range of +/- .031". For example, a 1/2" collet can hold any part ranging in size from 0.531" diameter down to 0.469" diameter
- Extremely accurate-total system accuracy (chuck and collet) of 0.0004" TIR or better
- Available with smooth or serrated ID. Hex, square and custom sizes also available, please call
- Vulcanized rubber between collet segments provide excellent sealing protection against coolant penetration



Royal Quick-Grip™ Collets Are Fully Compatible With MicroCentric™ & Hainbuch™ Quick-Change Collets!

### QG-42 Collets \$234.22 Each

Diameter	Smooth Bore	Serrated Bore
3/16	ROY-44101	-
7/32	ROY-44102	-
1/4	ROY-44103	-
9/32	ROY-44104	-
5/16	ROY-44105	-
11/32	ROY-44106	ROY-44155
3/8	ROY-44107	ROY-44156
13/32	ROY-44108	ROY-44157
7/16	ROY-44109	ROY-44158
15/32	ROY-44110	ROY-44159
1/2	ROY-44111	ROY-44160
17/32	ROY-44112	ROY-44161
9/16	ROY-44113	ROY-44162
19/32	ROY-44114	ROY-44163
5/8	ROY-44115	ROY-44164
21/32	ROY-44116	ROY-44165

Diameter	Smooth Bore	Serrated Bore
11/16	ROY-44117	ROY-44166
23/32	ROY-44118	ROY-44167
3/4	ROY-44119	ROY-44168
25/32	ROY-44120	ROY-44169
13/16	ROY-44121	ROY-44170
27/32	ROY-44122	ROY-44171
7/8	ROY-44123	ROY-44172
29/32	ROY-44124	ROY-44173
15/16	ROY-44125	ROY-44174
31/32	ROY-44126	ROY-44175
1	ROY-44127	ROY-44176
1-1/32	ROY-44128	-
1-1/16	ROY-44129	ROY-44177
1-3/32	ROY-44130	-
1-1/8	ROY-44131	ROY-44178
1-5/32	ROY-44132	-

Diameter	Smooth Bore	Serrated Bore
1-3/16	ROY-44133	ROY-44179
1-7/32	ROY-44134	-
1-1/4	ROY-44135	ROY-44180
1-9/32	ROY-44136	-
1-5/16	ROY-44137	ROY-44181
1-11/32	ROY-44138	-
1-3/8	ROY-44139	ROY-44182
1-13/32	ROY-44140	-
1-7/16	ROY-44141	ROY-44183
1-15/32	ROY-44142	-
1-1/2	ROY-44143	ROY-44184
1-17/32	ROY-44144	-
1-9/16	ROY-44145	ROY-44185
1-19/32	ROY-44146	-
1-5/8	ROY-44147	ROY-44186

### QG-65 Collets \$287.14 Each

Diameter	Smooth Bore	Serrated Bore
3/16	ROY-44201	-
7/32	ROY-44202	-
1/4	ROY-44203	-
9/32	ROY-44204	-
5/16	ROY-44205	-
11/32	ROY-44206	ROY-44306
3/8	ROY-44207	ROY-44307
13/32	ROY-44208	ROY-44308
7/16	ROY-44209	ROY-44309
15/32	ROY-44210	ROY-44310
1/2	ROY-44211	ROY-44311
17/32	ROY-44212	ROY-44312
9/16	ROY-44213	ROY-44313
19/32	ROY-44214	ROY-44314
5/8	ROY-44215	ROY-44315
21/32	ROY-44216	ROY-44316
11/16	ROY-44217	ROY-44317
23/32	ROY-44218	ROY-44318
3/4	ROY-44219	ROY-44319
25/32	ROY-44220	ROY-44320
13/16	ROY-44221	ROY-44321
27/32	ROY-44222	ROY-44322
7/8	ROY-44223	ROY-44323
29/32	ROY-44224	ROY-44324
15/16	ROY-44225	ROY-44325
31/32	ROY-44226	ROY-44326
1	ROY-44227	ROY-44327

Diameter	Smooth Bore	Serrated Bore
1-1/32	ROY-44228	-
1-1/16	ROY-44229	ROY-44328
1-3/32	ROY-44230	-
1-1/8	ROY-44231	ROY-44329
1-5/32	ROY-44232	-
1-3/16	ROY-44233	ROY-44330
1-7/32	ROY-44234	-
1-1/4	ROY-44235	ROY-44331
1-9/32	ROY-44236	-
1-5/16	ROY-44237	ROY-44332
1-11/32	ROY-44238	-
1-3/8	ROY-44239	ROY-44333
1-13/32	ROY-44240	-
1-7/16	ROY-44241	ROY-44334
1-15/32	ROY-44242	-
1-1/2	ROY-44243	ROY-44335
1-17/32	ROY-44244	-
1-9/16	ROY-44245	ROY-44336
1-19/32	ROY-44246	-
1-5/8	ROY-44247	ROY-44337
1-21/32	ROY-44248	-
1-11/16	ROY-44249	ROY-44338
1-23/32	ROY-44250	-
1-3/4	ROY-44251	ROY-44339
1-25/32	ROY-44252	-
1-13/16	ROY-44253	ROY-44340
1-27/32	ROY-44254	-

Diameter	Smooth Bore	Serrated Bore
1-7/8	ROY-44255	ROY-44341
1-29/32	ROY-44256	-
1-15/16	ROY-44257	ROY-44342
1-31/32	ROY-44279	-
2	ROY-44258	ROY-44343
2-1/32	ROY-44259	-
2-1/16	ROY-44260	ROY-44344
2-3/32	ROY-44261	-
2-1/8	ROY-44262	ROY-44345
2-5/32	ROY-44263	-
2-3/16	ROY-44264	ROY-44346
2-7/32	ROY-44265	-
2-1/4	ROY-44266	ROY-44347
2-9/32	ROY-44267	-
2-5/16	ROY-44268	ROY-44348
2-11/32	ROY-44269	-
2-3/8	ROY-44270	ROY-44349
2-13/32	ROY-44271	-
2-7/16	ROY-44272	ROY-44350
2-15/32	ROY-44273	-
2-1/2	ROY-44274	ROY-44351
2-17/32	ROY-44275	-
2-9/16	ROY-44276	ROY-44352
2-19/32	ROY-44277	-
2-5/8	ROY-44278	-

## COLLET INSTALLATION TOOL

- Easy to use tool enables collets to be changed in seconds
- Simply insert the steel pins into the collet face holes and squeeze main trigger to collapse collet
- Once collet is positioned within the chuck, squeeze the trigger lock to expand and release
- Heavy -duty construction for durability

Collet Series	Part Number	Price
QG-42	ROY-44097	\$550.00
QG-65	ROY-44098	\$539.00



Call Us Or Visit Our Website For Our Complete Selection!



# COLLET CHUCKS & ACCESSORIES

## 5C COLLET CHUCK

For Mounting With Adapter Plate  
6,000 RPM, 0.0004" T.I.R.

- Designed for use with 5C collets
- High quality forged steel body
- For turning, facing, boring, grinding and milling operations on center lathes and grinding machines
- Key operated scroll provides uniform, distortion-free clamping
- Scroll and pinions are hardened and ground for precision and long life

*Low Profile & Lightweight Design!*



5C Collet Chucks-5" Diameter

Spindle	Part Number	Price
Plain Back	BI-7862-0501	\$487.80
D1-4	BI-7862-0511	\$868.50
D1-5	BI-7862-0512	\$869.40
Plain Back TL*	BI-7862-0503	\$984.60

\*Tru-Length: No workpiece movement

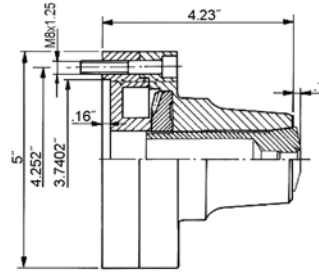

5" Machined Adapter Plates For Plain Back Chucks

Spindle	Part Number	Price
A-6	BI-7877-056	\$219.60
A-8	BI-7877-058	\$218.70
D1-4	BI-7878-054F	\$218.70
D1-5	BI-7878-055F	\$218.70
D1-6	BI-7878-056F	\$218.70
2-3/16-10	BI-7922-053	\$123.30

## SUPER PRECISION 5C SET TRU COLLET CHUCK

With Fine Adjustment-For Mounting With Adapter Plate  
6,000 RPM, 0.0004" T.I.R.

- Designed for use with 5C collets
- High quality forged steel body
- For turning, facing, boring, grinding and milling operations on center lathes and grinding machines
- Key operated scroll provides uniform, distortion-free clamping
- Four fine adjustment screws are used to set up the chuck on it's mounting plate to get precision within 0.0004" TIR

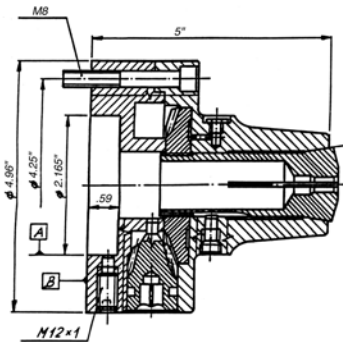

5" Machined Adapter Plates

Spindle	Part Number	Price
A-4	BI-7874-054	\$217.80
A-5	BI-7874-055	\$217.80
A-6	BI-7874-056	\$217.80
D1-4	BI-7875-054	\$327.60
D1-5	BI-7875-055	\$352.80
D1-6	BI-7875-056	\$359.10
2-3/16x10	BI-7876-054	\$169.20

5C Set Tru Collet Chucks

Chuck Dia	RPM	Part Number	Price
5"	6000	BI-7862-0505	\$724.50

## 5C COLLET CHUCKS



- Made in Poland
- All forged steel bodies
- 5" diameter
- Plain back
- Max speed: 6,000 RPM
- Tru-Length type features fixed collet position for fast and accurate workpiece changes

Description	Part Number	Price
Plain Back	BI-3862-0501P	\$390.42
Plain Back TL*	BI-3862-0503P	\$689.13

## 5C COLLET CHUCKS

Hold O.D. In Power/Manual Chucks



For short runs using a 5C collet, chuck this collet holder and you're ready to go! Lock, 1/2 turn and release at the front: heavy-duty, all-steel, hardened and ground. Saves you time! Drilled and tapped holes at rear of collet chuck for mounting to a plate. Has a thru-hole and can be used with a collet stop screwed onto the ID threads of collet.



Description	OD	Weight	Part Number	Price
5C Collet Chuck	3"	6 lbs	KAL-1CC	\$399.00

## 5C, 16C & 3J MANUAL COLLET FIXTURES



- Opened and closed via an internal cam mechanism
- Accu-Length™ operation – collet and workpiece position remains fixed for precise length control
- Can be used in stationary and rotary table applications, not for use on lathes or grinders above 5 RPM!
- All models configured for both four and six-slot mounting - 4.125" bolt circle diameter
- All models include cam wrench

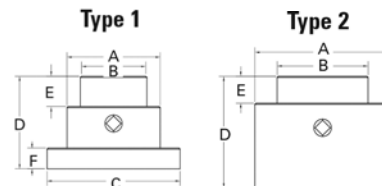

Collet Type	Cap.	A	B	C	D	E	F	Type	Part Number	Price
5C	1-1/16"	3.37	2.50	4.95	3.50	1.15	0.75	1	ROY-62002	\$713.79
16C	1-5/8"	4.95	3.35	-	4.63	1.50	-	2	ROY-62006	\$1,076.35
3J	1-3/4"	4.95	3.35	-	4.13	1.00	-	2	ROY-62008	\$1,076.35



Call Us Today For All Of Your Machine Tool Needs!