

CHUCK JAWS
LATHE WORKHOLDING

MACHINE VISES
VISE JAWS

RETENTION KNOBS
ER, DA, TG COLLETS

TOOLHOLDERS
TAP HOLDERS

INDEXABLE DRILLS
TURNING & BORING

ENDMILLS, DRILLS
TAPS & REAMERS

ABRASIVES
MEASURING TOOLS

MRO & SAFETY
FLAT STOCK/DRILL ROD

TAPPING ARMS

QUICK TAP TAPPING ARM

For Small To Medium Size Taps

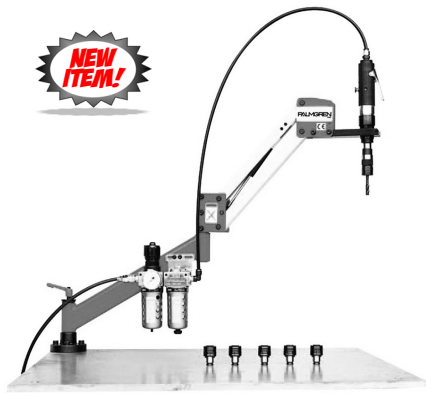

Palmgren's Quick-Tap pneumatic tapping machine is suitable for small and medium size taps. The arm is equipped with lubricated for life bearings at all swivel points, provides weightless operation through the use of gas counter balance springs and permits the operator to bring the tap to the hole with ease.

Standard Equipment

- Parallel arm with 4" to 37" reach
- Stationary bench bracket
- Quick change tooling adaptor
- Air preparation unit with lubricator, filter, regulator and pressure gauge
- Vertical motor bracket
- High torque reversible air motor



See Page 228
For Tap Collets

Tap Capacity		Mild Steel	Aluminum	Motor RPM	Torque @ 90 psi	Air Cons. (CFM)	Tap Collet Series	Model #	Part Number	Price Each
1/2"	9/16"	400	27 ft/lb	24	1	QT400	PALM-80420	\$2,420.00		
3/8"	1/2"	700	16ft/lb	24	1	QT700	PALM-80421	\$2,420.00		

SHOP TAP TAPPING ARM

Medium Duty General Purpose

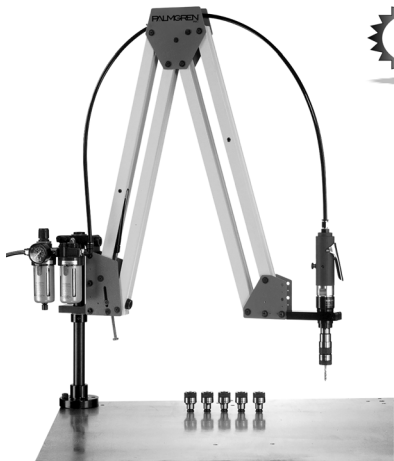

Palmgren's Shop-Tap pneumatic tapping machine is a medium duty general purpose machine suitable for tapping small to medium size taps. The arm is equipped with lubricated for life bearings at all swivel points, provides weightless operation through the use of gas counter balance springs and permits the operator to bring the tap to the hole with ease.

Standard Features

- Parallel arm with 20" to 62" reach
- Stationary bench bracket
- Quick change tooling adaptor
- Air preparation unit with lubricator, filter, regulator and pressure gauge
- Vertical motor bracket
- High torque reversible air motor



See Page 228
For Tap Collets

Tap Capacity		Mild Steel	Aluminum	Motor RPM	Torque @ 90 psi	Air Cons. (CFM)	Tap Collet Series	Model #	Part Number	Price Each
1/2"	9/16"	400	27 ft/lb	24	1	ST400	PALM-80400	\$2,625.00		
3/8"	1/2"	700	16ft/lb	24	1	ST700	PALM-80401	\$2,625.00		

FlexArm

FLEXIBLE ARM TAPPING MACHINES

Save Money • Save Time • Reduce Tap Breakage

FlexArm



Time & Tap Life

FlexArm's torque clutch holders make tapping blind holes easy. It even taps on parts that can't be easily tapped by other methods. The torque clutch allows the tap to stop turning when it encounters any obstruction that might cause tap breakage and is adjustable for all types of material. FlexArm's quick-change chuck allows you to change from one size tap to another in 3 to 5 seconds. No gears, head height or stops to change. The FlexArm is ideally suited for tapping large and multi-level parts, and can be adjusted to stay where it is positioned or automatically return to the home (folded) position. The result is less operator strain and increased production.

APPLICATIONS:

- Tapping/ Reaming • Chamfer
- Countersink • Deburring
- Drill (soft materials)
- Retap (warped heat-treated holes)

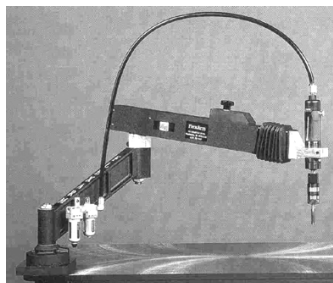

Model A-32

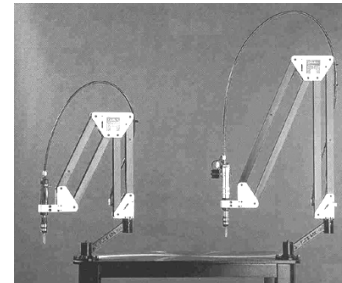

Model S-36

Model M-60

Each FlexArm Tapping Machine Comes Complete With:

- 400 RPM reversible motor with tap capacity up to 9/16"
- Angle mount
- Filter
- Lubricator
- Quick change chuck

Tap Capacity In Steel	Working Range	Motor RPM	Tap Collet Series	Torque (ft.lbs)	Part Number	Price Each
0-80 to 9/16	11" to 34"	400	1	28	FLEX-T4-A32	\$2,895.00
	14" to 51"	400	1	28	FLEX-S36-FX9-110	\$3,600.00
	22" to 76"	400	1	28	FLEX-M60-FX9-110	\$3,800.00

All FlexArm Tapping Machines Include a One Year Limited Warranty on the complete unit. (Does not include tap holders and some motor replacement parts). Repair service also available.

Call Us Today For All Of Your Machine Tool Needs!