

# LATHE WORKHOLDING

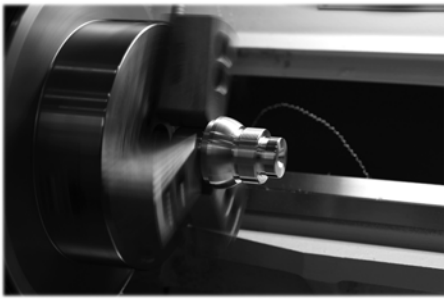

**IN THIS SECTION:**

- CNC Lathe Chucks.....66-72
- Hydraulic Cylinders.....73
- Manual/Scroll Chucks.....74-86
- Collet Chucks.....87-92
- Live & Dead Centers.....93-101
- Bar Pullers.....102-105
- 3J/16C/5C Collets.....106-109
- ID Workholding.....110-113
- Lathe Bushings.....114-118

## N-200A SERIES CHUCKS-3 JAW 1.5mm x 60° Serrations Power Chucks With Adaptor Plate



- **STRONG® N-200 Series Chucks Are Interchangeable with Kitagawa® B-200 Series Chucks**
- Over 30 years of innovative manufacturing experience
- ISO 9002 and MCS certification
- Rigid inspection process to ensure finished product quality
- 2, 3 & 4 jaw and Extra Large Bore chucks
- OEM on Victor, Okuma, & Leadwell and many other turning centers
- Higher gripping force and larger bore compared to standard chucks
- **STRONG®** Hydraulic cylinders, master jaws, chip covers, wedge plungers, threaded drawnuts, chuck wrenches and adapter plates are available and interchange with Kitagawa® B-200 Series chucks

**FEATURES:**

- Approx. 20% higher speed, higher gripping force and larger bore compared with usual chucks
- Model N-200A chucks are assembled with adapter for ASA B5.9 type A spindles
- Model N-200A chucks are manufactured from high grade alloy steel
- All sliding surfaces are hardened and ground for accuracy and repeatability
- Chucks include all mounting hardware
- Additional charge for threaded drawnut

**Strong N Series Chucks Are Interchangeable With Kitagawa® B200 Series Chucks!**

**Chucks Includes:**  
1.5mm x 60° Master Jaws  
Blank Drawnut • Soft Top Jaws  
T-Nuts • Mounting Bolts • Wrench

Chuck Size	Chuck Model	Chuck Dia.	Thru-hole Dia.	Mount	Part Number	Price Each	Chuck Cross Reference
5"	N205	5.315"	1.299"	Flatback	K-205-N-B	\$1,592.00	B-205, HS-05
				A2-4	K-205A04-N-B	\$1,752.00	
				A2-5	K-205A05-N-B	\$1,752.00	
6"	N206	6.654"	1.772"	Flatback	K-206-N-B	\$1,592.00	B206, ATL6, HS-06
				A2-4	K-206A04-N-B	\$1,781.00	
				A2-5	K-206A05-N-B	\$1,781.00	
8"	N208	8.268"	2.047"	Flatback	K-208-N-B	\$1,905.00	B208, ATL8, HS-08
				A2-5	K-208A05-N-B	\$2,040.00	
				A2-6	K-208A06-N-B	\$2,040.00	
10"	N210	10.000"	2.953"	Flatback	K-210-N-B	\$2,387.00	B210, ATL10, HS-10
				A2-6	K-210A06-N-B	\$2,678.00	
				A2-8	K-210A08-N-B	\$2,678.00	
12"	N212	11.969"	3.585"	A2-6	K-212A06-N-B	\$3,600.00	B212, ATL12, HS-12
				A2-8	K-212A08-N-B	\$3,600.00	
15"	N215	15.000"	4.626"	A2-8	K-215A08-N-B	\$4,839.00	B15
				A2-11	K-215A11-N-B	\$4,839.00	
18"	N218	17.717"	4.626"	A2-8	K-218A08-N-B	\$7,012.00	B18
				A2-11	K-218A11-N-B	\$7,012.00	

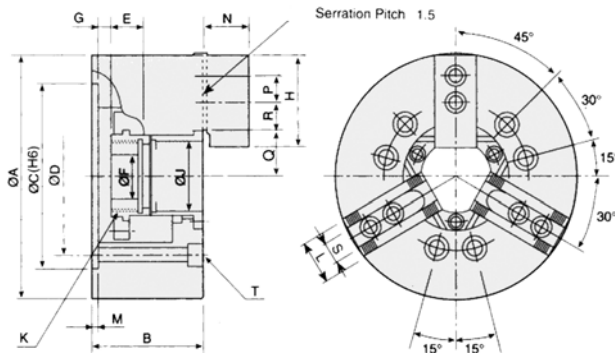

**Full Line Available!**  
Please call for more information

Specifications	N205	N206	N208	N210	N212	N215	N218
Through-Hole (mm)	Ø33	Ø45	Ø52	Ø75	Ø91	Ø117.5	Ø117.5
Plunger Stroke (mm)	10	12	16	19	23	23	23
Jaw Stroke (mm)	5.4	5.5	7.4	8.8	10.6	10.6	10.6
Max. Draw Bar Pull Force (kgf)	1700	2200	3400	4300	5500	7240	7240
Max. Gripping Force (kgf)	3600	5700	8800	11000	14300	18355	18355
kgf/cm2	29.6	28.5	26.5	27.5	27.5	23.5	23.5
Max. Speed (r.p.m.)	7000	6000	4900	4200	3300	2500	2000

\*Kitagawa is a registered trademark of Kitagawa NorthTech

**Call Us Today For All Of Your Machine Tool Needs!**



## NB-200 SERIES 3 JAW EXTRA LARGE BORE CHUCKS

1.5mm x 60° Serrations Power Chucks

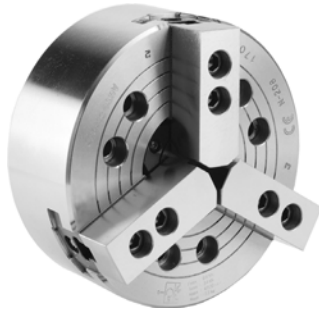

**Chucks Includes:**  
1.5mm x 60° Master Jaws  
Blank Drawnut • Soft Top Jaws  
T-Nuts • Mounting Bolts • Wrench

Chuck Size	Chuck Model	Chuck Dia.	Thru-hole Dia.	Mount	Part Number	Price Each	Chuck Cross Reference
6"	NB-206	6.654"	2.047"	A2-5	K-206A05-NB-B	\$2,060.00	BB206, MH-206
8"	NB-208	8.268"	2.598"	A2-6	K-208A06-NB-B	\$2,542.00	BB208, MH-208
10"	NB-210	10.000"	3.070"	A2-8	K-210A08-NB-B	\$2,918.00	BB210, MH-210
12"	NB-212	11.969"	4.803"	A2-8	K-212A08-NB-B	\$4,220.00	BB212, MH-212

**FEATURES:**

- Extra large bore
- Higher speed, gripping force and larger bore compared to other chucks
- Includes adapter plate
- Manufactured from high grade alloy steel
- All sliding surfaces are hardened and ground for accuracy and repeatability
- Chucks include all mounting hardware
- Additional charge for threaded drawnut

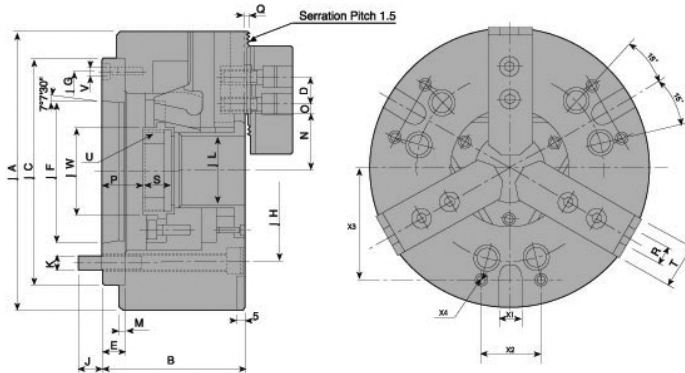

Model	Thru-hole (mm)	Plunger Stroke (mm)	Jaw Stroke (mm)	Max. Draw Bar Pull (kgf)	Max Gripping Force (kgf)	Max. Operating Pressure (kgf/cm <sup>2</sup> )	Max Speed (RPM)	Matching Cylinder	A	B	C	D	E	J	L	M
NB-206A05	52	12	5.4	2200	5700	18.4	6000	M1552	170	97	140	20	22	16	52	5
NB-208A06	66	16	7.4	3500	8973	20.5	4600	M1868	210	103	170	25	17	19.5	66	5
NB-210A08	78	19	8.8	4300	11000	27.5	4200	M1878	254	113	220	30	18	24	78	5
NB-212A11	122	23	10.6	5800	15000	20.5	3200	M2511	315	134	300	30	22	28	122	5

## VA-200 SERIES 3 JAW CLOSED CENTER CHUCKS

1.5mm x 60° Serrations Power Chucks



**Full Line Available!**  
Please call for more information.

Chuck Size	Chuck Model	Chuck Dia.	Mount	Part Number	Price Each	Chuck Cross Reference
6"	V206	6.654"	Flatback	K-206-V-B	\$1,128.60	N06, HC-06
			A2-4	K-206A05-V-B	\$1,326.60	
			A2-5	K-206A06-V-B	\$1,326.60	
8"	V208	8.268"	Flatback	K-208-V-B	\$1,480.05	N08, HC-08
			A2-5	K-208A05-V-B	\$1,727.55	
			A2-6	K-208A06-V-B	\$1,727.55	
10"	V210	10.000"	Flatback	K-210A-V-B	\$1,866.15	N10, HC-10
			A2-6	K-210A06-V-B	\$2,217.60	
			A2-8	K-210A08-V-B	\$2,217.60	
12"	V212	11.969"	A2-6	K-212A06-V-B	\$3,088.80	HC-12
			A2-8	K-212A08-V-B	\$3,088.80	
15"	V215	15.000"	A2-8	K-215A08-V-B	\$6,534.00	
			A2-11	K-215A11-V-B	\$5,671.00	

Model	Jaw Stroke (mm)	Plunger Stroke (mm)	Max. Pull Force (kgf)	Max. Gripping Force (kgf)	Max. Oper. Pressure (kgf/cm <sup>2</sup> )	Max. Speed	Weight (kg)	Moment of Inertia (kg?m <sup>2</sup> )	Matching Cylinder	Gripping O.D. Range (mm)
V-206	9.2	20	1835	5353	26.5	5200	12	0.045	MS105C	Ø18-Ø165
V-208	9.7	21	2549	7648	25.5	4500	23	0.137	MS125C	Ø26-Ø210
V-210	8.8	25	2957	11013	28.6	4000	34.5	0.3	MS125C	Ø26-Ø254
V-212	10.5	30	4181	15907	27.5	3300	59.5	0.725	MS150C	Ø26-Ø304
V-215	16	35	8362	25391	32.6	3000	101	1.8	MS200C	Ø68-Ø381
V-218	16	35	8362	25391	32.6	2700	116	2.9	MS200C	Ø130-Ø450
V-221	16	35	8362	27838	32.6	1940	181	6.2	MS200C	Ø65-Ø530
V-224	16	35	8362	27838	32.6	1760	216	7	MS200C	Ø152-Ø610
V-232	18.6	35	8362	27838	32.6	600	365	27.3	MS200C	Ø100-Ø810

Call Us Or Visit Our Website For Our Complete Selection!

# POWER CHUCKS

## NT-200 SERIES CHUCKS-2 JAW 1.5mm x 60° Serrations Power Chucks



Chuck Size	Chuck Model	Chuck Dia.	Thru-hole Dia.	Mount	Part Number	Price Each
5"	NT205	5.315"	1.299"	A2-4	K-T205A04-NT-B	\$2,024.00
				A2-5	K-T205A05-NT-B	
6"	NT206	6.654"	1.772"	A2-4	K-T206A04-NT-B	\$2,060.00
				A2-5	K-T206A05-NT-B	
8"	NT208	8.268"	2.047"	A2-5	K-T208A05-NT-B	\$2,478.00
				A2-6	K-T208A06-NT-B	
10"	NT210	10.000"	2.953"	A2-6	K-T210A06-NT-B	\$3,042.00
				A2-8	K-T210A08-NT-B	
12"	NT212	11.969"	3.585"	A2-6	K-T212A06-NT-B	\$3,774.00
				A2-8	K-T212A08-NT-B	

**Full Line Available!**  
Please call for more information.

**Chucks Includes:**  
1.5mm x 60° Master Jaws  
Blank Drawnut • Soft Top Jaws  
T-Nuts • Mounting Bolts • Wrench

Model	Thru-hole (mm)	Plunger Stroke (mm)	Jaw Stroke (mm)	Max. Draw Bar Pull (kgf)	Max Gripping Force (kgf)	Max. Operating Pressure (kgf/cm)	Max Speed (RPM)	Matching Cylinder
NT-205	33	10	5.4	1189	2447	19.5	7000	M1036
NT-206	45	12	5.5	1495	3875	18.9	6000	M1246
NT-208	52	16	7.4	2366	5975	18.4	5000	M1552
NT-210	75	19	8.8	2927	7546	18.4	4200	M1875
NT-212	91	23	10.6	3875	9789	18.4	3300	M2091

## NIT-200 SERIES CHUCKS-4 JAW 1.5mm x 60° Serrations Power Chucks



Chuck Size	Chuck Model	Chuck Dia.	Thru-hole Dia.	Mount	Part Number	Price Each
6"	NIT206	6.653"	1.772"	A2-5	K-F206A5-NIT-B	\$2,397.00
				A2-6	K-F208A06-NIT-B	
8"	NIT208	8.268"	2.047"	A2-5	K-F208A05-NIT-B	\$3,187.00
				A2-6	K-F208A06-NIT-B	
10"	NIT210	10.000"	2.953"	A2-6	K-F210A06-NIT-B	\$3,624.00
				A2-8	K-F210A08-NIT-B	
12"	NIT212	11.969"	3.585"	A2-6	K-F212A06-NIT-B	\$4,426.00
				A2-8	K-F212A08-NIT-B	

**Chucks Includes:**  
1.5mm x 60° Master Jaws  
Blank Drawnut • Soft Top Jaws  
T-Nuts • Mounting Bolts • Wrench

**Full Line Available!**  
Please call for more information.

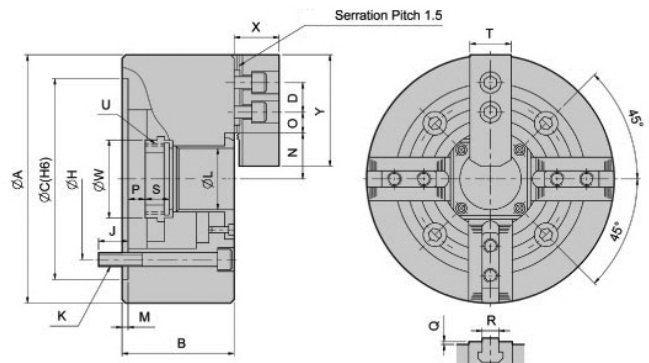

Model	Thru-hole (mm)	Plunger Stroke (mm)	Jaw Stroke (mm)	Max. Draw Bar Pull (kgf)	Max Gripping Force (kgf)	Max. Operating Pressure (kgf/cm)	Max Speed (RPM)	Matching Cylinder
NIT-206	45	12	5.5	2243	5812	28.5	4500	M1246
NIT-208	52	16	7.4	3558	9075	26.5	3600	M1552
NIT-210	75	19	8.8	4385	11319	27.5	3200	M1875
NIT-212	91	23	10.6	5812	14990	27.5	2700	M2091

Model	A	B	C (H6)	D	H	J	K	L	M	N max.	O max.	O min.	P max.	P min.	Q	R	S	T	U max.	W	X	Y
NIT-206	169	81	140	20	104.78	16	4-M10x80	45	5	32	22.75	9.25	11	-1	2	12	19	31	M55X2	60	37	73
NIT-208	210	91	170	25	133.35	20	4-M12x90	52	5	38.7	29.75	14.75	14.5	-1	2	14	20.5	35	M60X2	66	38	95
NIT-210	254	100	220	30	171.45	22	4-M16x100	75	6	51	33.75	14.25	8.5	-10.5	2	16	25	40	M85X2	94	43	110
NIT-212	304	110	220	30	171.45	23	4-M16x110	91	6	61.3	45.75	15.75	8	-15	2	21	28	50	M100X2	108	51	130
NIT-215	381	133	300	43	235	35	4-M20x135	117.5	6	82	45.25	16.75	7	-16	5	22	43	62	M130X2	139	66	165

Call Us Today For All Of Your Machine Tool Needs!

## SAMCHULLY HS SERIES

### Standard 3-Jaw High Speed Open Center Chucks



Known worldwide for excellent quality, Samchully produces power chucks, hydraulic cylinders and scroll chucks. Samchully Machinery Co., Ltd. has achieved and maintains its' ISO 9001, and CE Mark certifications. Power chucks and hydraulic cylinders for CNC lathes manufactured by Samchully are standard equipment in products made by **Hyundai-KIA** and **Doosan** (Korea's top machine tools manufacturers). Samchully is also a major supplier of chuck systems to **HAAS Automation, Inc.**

- Samchully HS series chucks are interchangeable with Kitagawa® B200 series chucks
- Samchully HCH series chucks are interchangeable with Kitagawa® B series chucks
- Samchully MH and Kitagawa® BB (Large Bore) series share the same specifications
- Samchully HT series chucks are interchangeable with Kitagawa® BT series chucks

#### FEATURES:

- 3-jaw, wedge-type chuck with large bore
- Powerful gripping force and high turning speed
- Manufactured from high grade alloy steel
- All sliding surfaces are hardened and ground for accuracy and repeatability
- 2 & 4 jaw and Mega Bore chucks also available
- Large variety of replacement parts in stock

Chuck Size	Chuck Model	Thru-hole Dia	Mount	Part Number	Price	Chuck Cross Reference
5"	HS-05	1.290" (33mm)	Flatback	K-205-HS-H	CALL	B-205, N205 HS-05
			A2-5	K-205A5-HS-H	CALL	
6"	HS-06	1.77" (46mm)	Flatback	K-206-HS-H	CALL	B206, N206 ATL6, HS-06
			A2-5	K-206A05-HS-H	CALL	
8"	HS-08	2.047" (52mm)	Flatback	K-208-HS-H	CALL	B208, N208 ATL8, HS-08
			A2-6	K-208A06-HS-H	CALL	
10"	HS-10	2.952" (77mm)	Flatback	K-210-HS-H	CALL	B210, N210 ATL10, HS-10
			A2-6	K-210A06-HS-H	CALL	
			A2-8	K-210A08-HS-H	CALL	
12"	HS-12	3.583" (91mm)	Flatback	K-212-HS-H	CALL	B212, N212 ATL12, HS-12
			A2-6	K-212A06-HS-H	CALL	
			A2-8	K-212A08-HS-H	CALL	

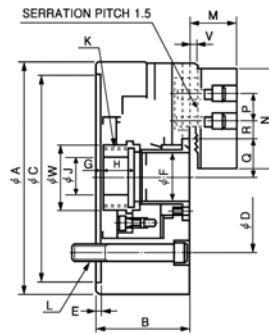
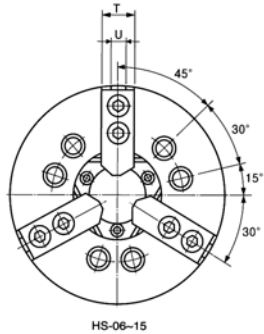

Model	A	B	C (H6)	D	E	F	G max.	G min.	H	J	K max.
HS-05	135	60	110	82.6	4	33	1	-9	20	12	M40X1.5
HS-06	169	81	140	104.8	5	46	11	-1	19	20	M55X2.0
HS-08	210	91	170	133.4	5	52	14.5	-1.5	20.5	30	M60X2.0
HS-10	254	100	220	171.4	5	77	8.5	-10.5	25	45	M85X2.0
HS-12	304	110	220	171.4	6	91	8	-15	28	50	M100X2.0

Model	L	M	N	P	O max.	Q min.	R max.	R min.	T	U	V	W
HS-05	3-M10X60	26	54	14	26.5	23.8	19.75	7.75	23	10	2	45
HS-06	6-M10X95	29	72	20	32	29.25	22.75	9.25	31	12	2	60
HS-08	6-M12X105	39	95	25	38.7	35	29.75	14.75	35	14	2	66
HS-10	6-M16X120	43	110	30	51	46.6	33.75	14.25	40	16	2	94
HS-12	6-M16X130	51	111	30	61.3	56	45.75	15.75	49	21	2	108

## SAMCHULLY HCH SERIES

### Standard 3-Jaw, Wedge-Type Open Center Chucks



- 3-jaw, wedge-type chuck with large bore
- Powerful gripping force and high turning speed
- Manufactured from high grade alloy steel
- All sliding surfaces are hardened and ground for accuracy and repeatability
- 2 & 4 jaw and Mega Bore chucks also available
- Large variety of replacement parts in stock

Chuck Size	Chuck Model	Thru-hole Dia	Mount	Part Number	Price	Chuck Cross Reference
6"	HCH-06	1.300 33mm	Flatback	K-06-HCH-H	CALL	B-06
			A2-5	K-06A05-HCH-H	CALL	
8"	HCH-08	1.811 46mm	Flatback	K-08-HCH-H	CALL	B-08
			A2-6	K-08A06-HCH-H	CALL	
10"	HCH-10	2.559 65mm	Flatback	K-10-HCH-H	CALL	B-10
			A2-6	K-10A06-HCH-H	CALL	
12"	HCH-12	3.070 78mm	Flatback	K-12-HCH-H	CALL	B-12
			A2-8	K-12A08-HCH-H	CALL	
15"	HCH-15	4.626 117.5mm	Flatback	K-15-HCH-H	CALL	B-15
18"	HCH-18	4.626 117.5mm	Flatback	K-18-HCH-H	CALL	B-18
			A2-11	K-18A11-HCH-H	CALL	
21"	HCH-21	5.511 140mm	Flatback	K-21-HCH-H	CALL	B-21
			A2-11	K-21A11-HCH-H	CALL	
24"	HCH-24	6.496 165mm	Flatback	K-24-HCH-H	CALL	B-24
			A2-15	K-24A11-HCH-H	CALL	
32"	HCH-32	9.448 240mm	Flatback	K-32-HCH-H	CALL	-
			A2-15	K-32A15-HCH-H	CALL	

Call Us Or Visit Our Website For Our Complete Selection!

# POWER CHUCKS

## SAMCHULLY MH SERIES

### Mega Bore 3-Jaw High Speed Open Center Chucks



- 3-jaw, wedge-type, large bore, open center chuck
- Powerful gripping force and high turning speed
- Manufactured from high grade alloy steel
- All sliding surfaces are hardened and ground for accuracy and repeatability

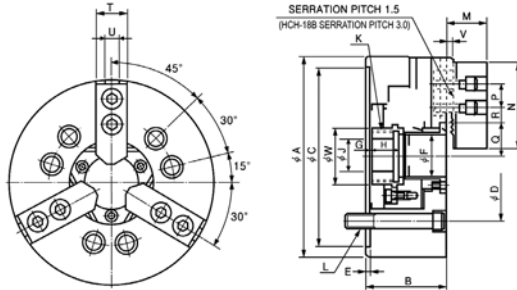

Chuck Size	Chuck Model	Thru-hole Dia	Mount	Part Number	Price	Chuck Cross Reference
6"	MH-206	2.047 52mm	Flatback	K-206-MH-H	CALL	BB-206
			A2-5	K-206A05-MH-H	CALL	
			A2-6	K-206A06-MH-H	CALL	
8"	MH-208	2.598 66mm	Flatback	K-208-MH-H	CALL	BB-208
			A2-5	K-208A05-MH-H	CALL	
			A2-6	K-208A06-MH-H	CALL	
10"	MH-210	3.228 82mm	Flatback	K-210-MH-H	CALL	BB-210
			A2-6	K-210A06-MH-H	CALL	
			A2-8	K-210A08-MH-H	CALL	
12"	MH-212	4.055 103mm	Flatback	K-212-MH-H	CALL	BB-212
			A2-8	K-212A08-MH-H	CALL	

MODEL	A	B	C(H6)	D	E	F	G max	G min	H	J	K max
HH-206	175	81	140	104.8	5	56	14	-1	17.5	20	M60X2.0
HH-208	210	91	170	133.4	5	66	7.5	-10	27	30	M75X2.0
HH-210	254	100	220	171.4	5	82	8.5	-11	25	52	M90X2.0
HH-212	315	110	300	235	6	103	8	-15	28	66	M112X2.0

MODEL	L	M	N	P	Q max	Q min	R max	R min	T	U	V	W
HH-206	3-M10X95	33	72	20	38	34.8	21.75	10.25	31	12	2	65
HH-208	6-M12X115	39	95	25	45.7	42	23.75	11.75	35	14	2	80
HH-210	6-M16X120	43	110	30	54.5	50.1	32.25	14.25	40	16	2	101
HH-212	6-M20X130	51	111	30	67.3	62	45.75	15.75	49	21	2	124

## SAMCHULLY HST SERIES

### Standard 2-Jaw High Speed Open Center Chucks



- 2-jaw, wedge-type open center chuck
- Powerful gripping force and super-high turning speed
- Manufactured from high grade alloy steel
- All sliding surfaces are hardened and ground for accuracy and repeatability

Chuck Size	Chuck Model	Thru-hole Dia	Mount	Part Number	Price	Chuck Cross Reference
6"	HST-06	46mm	Flatback	K-T206-HST-H	CALL	BT-206, NT206, HST06
			A2-5	K-T206A05-HST-H	CALL	
8"	HST-08	52mm	Flatback	K-T208-HST-H	CALL	BT-208, NT208, HST08
			A2-8	K-T208A08-HST-H	CALL	
10"	HST-10	77mm	Flatback	K-T210-HST-H	CALL	BT-210, NT210, HST-10
			A2-6	K-T210A06-HST-H	CALL	
12"	HST-12	91mm	Flatback	K-T212-HST-H	CALL	BT-212, NT212, HST12
			A2-8	K-T212-A08-HST-H	CALL	



## COMPLETE WORKHOLDING SOLUTIONS!

- Open and closed center chucks
- Extra large thru-hole chucks
- Draw down chucks
- Swing lock chucks
- Adapter plates
- Threaded drawnuts-standard and extended length
- Hydraulic cylinders



**PLEASE CALL FOR MORE INFORMATION!**

**Call Us Today For All Of Your Machine Tool Needs!**

**Full Line Available!**  
Please call for more information.

### B200 SERIES 3-JAW POWER CHUCKS

Kitagawa® power chucks deliver up to 20% more speed, gripping force and bore size when compared to conventional chucks. The B200 Series delivers consistent accuracy and repetitive chucking. B200 and BT200 Series Chucks are manufactured from high grade alloy steel. All sliding surfaces are hardened and ground to assure consistent accuracy and performance.



Chuck Size	Chuck Model	Thru-hole Dia	Mount	Part Number	Price	Chuck Cross Reference
4"	B-204	1.023" (26mm)	Flatback	K-204-B-K	<b>PLEASE CALL FOR CURRENT PRICING</b>	-
5"	B-205	1.290" (33mm)	Flatback	K-205-B-K		N205 HS-05
6"	B-206	1.771" (45mm)	Flatback	K-206-B-K		N206 ATL6, HS-06
8"	B-208	2.047" (52mm)	Flatback	K-208-B-K		N208 ATL8, HS-08
10"	B-210	2.952" (75mm)	Flatback	K-210-B-K		N210 ATL10, HS-10
12"	B-212	3.583" (91mm)	Flatback	K-212-B-K		N212 ATL12, HS-12

\*Adapter Plates Sold Separately

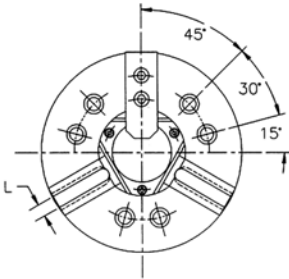

Model	B204	B205	B206	B208	B210	B210	B212
Spindle Nose	3.346	4.331	A2-5	A2-6	A2-6	A2-8	A2-6
Thru - Hole	in 1.024	1.299	1.772	2.047	2.953	2.953	3.583
Jaw Stroke (dia)	in 0.213	0.213	0.217	0.291	0.346	0.346	0.417
Plunger Stroke	in 0.394	0.394	0.472	0.63	0.748	0.748	0.906
Max Draw Bar Pull Force	lbs 3142	3590	4846	7808	9471	9471	12115
Max Gripping Force	lbs 6393	8076	12555	19292	24449	24449	31718
Max Speed	rpm 8000	7000	6000	5000	4200	4200	3300
Net Weight	lbs 8.8	14.7	27.1	48.5	81.1	75.1	122.9
Accuracy - T.I.R.	0.0008	0.0008	0.0008	0.0008	0.0008	0.0008	0.0008
Matching Cylinder	S1036	S1036	S1246	S1552	S1875	S1875	S2091

### BB-200 SERIES SUPER LARGE BORE 3 JAW POWER CHUCKS



Chuck Size	Chuck Model	Chuck Dia.	Thru-hole Dia.	Mount	Part Number	Price Each
6"	BB206	6.693"	2.087" (53mm)	Flatback	K-206-BB-K	<b>PLEASE CALL FOR CURRENT PRICING</b>
8"	BB208	8.268"	2.598" (66mm)	Flatback	K-208-BB-K	
10"	BB210	10.000"	3.189" (81mm)	Flatback	K-210-BB-K	
12"	BB212	12.402"	4.173" (106mm)	Flatback	K-212-BB-K	

\*Adapter Plates Sold Separately

### BT-200 SERIES 2-JAW POWER CHUCKS



Chuck Size	Chuck Model	Chuck Dia.	Thru-hole Dia.	Mount	Part Number	Price Each
4"	BT204	4.331"	1.024"	Flatback	K-T204-BT-K	<b>PLEASE CALL FOR CURRENT PRICING</b>
5"	BT205	5.315"	1.299"	Flatback	K-T204-BT-K	
6"	BT206	6.654"	1.772" (45mm)	Flatback	K-T206-BT-K	
8"	BT208	8.268"	2.047" (52mm)	Flatback	K-T208-BT-K	
10"	BT210	10.000"	2.953" (75mm)	Flatback	K-T210-BT-K	
12"	BT212	11.969"	3.583" (91mm)	Flatback	K-T212-BT-K	

\*Adapter Plates Sold Separately

Call Us Or Visit Our Website For Our Complete Selection!

# POWER CHUCK ACCESSORIES

TABLE OF CONTENTS

## CHUCK ACCESSORIES AND REPLACEMENT PARTS

STRONG® replacement parts and accessories are interchangeable with Kitagawa® B200 series chucks. Samchully replacement parts also available.

1. Chuck body
2. Wedge plunger
3. Master jaws
4. Soft top jaws
5. T-nuts
6. Chip cover
7. Drawnut
- 7-1. Drawtube
8. Plunger nut
- 9/9-1 Chuck wrench w/ handle

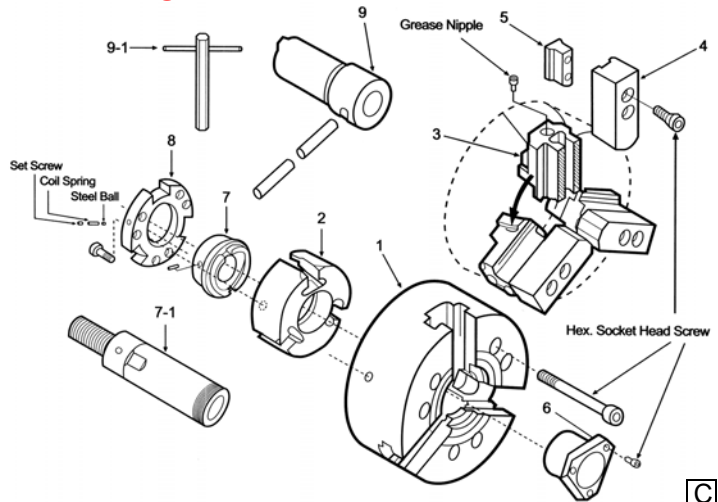

# Strong KITAGAWA

For Kitagawa® and Strong® Power Chucks

Kitagawa® or Strong Chuck Model	Strong N204 *For Strong Chucks Only*		Strong N205 *For Strong Chucks Only*		Kitagawa® B206 Strong N206		Kitagawa® B208 Strong N208	
Item	Part Number	Price Each	Part Number	Price Each	Part Number	Price Each	Part Number	Price Each
Wedge Plunger (2)	K-WP204-N-B	\$256.80	K-WP205-N-B	\$256.80	K-WP206-N-B	\$285.00	K-WP208-N-B	\$342.00
Blank Drawnut (7)	K-D204BLN-B	\$75.00	K-D205BLN-B	\$75.00	K-D206BLN-B	\$85.00	K-D208BLN-B	\$100.00
Master Jaws Set (3)	K-MJ204-N-B	\$851.00	K-MJ205-N-B	\$851.00	K-MJ206-N-B	\$904.00	K-MJ208-N-B	\$1,017.00
Plunger Nut (8)	K-PN204-N-B	\$188.10	K-PN205-N-B	\$188.10	K-PN206-N-B	\$128.00	K-PN208-N-B	\$257.00
Chip Cover (6)	K-CP204-N-B	\$132.00	K-CP205-N-B	\$132.00	K-CP206-N-B	\$100.00	K-CP208-N-B	\$120.00
Chuck Wrench (9)	K-CW204-N-B	\$159.50	K-CW205-N-B	\$155.00	K-CW206-N-B	\$141.00	K-CW208-N-B	\$168.00

Kitagawa® or Strong Chuck Model	Kitagawa® B210 Strong N210		Kitagawa® B212 Strong N212		Kitagawa® B15 Strong N215		Kitagawa® B18 Strong N218	
Item	Part Number	Price Each	Part Number	Price Each	Part Number	Price Each	Part Number	Price Each
Wedge Plunger (2)	K-WP210-N-B	\$375.00	K-WP212-N-B	\$592.00	K-WP215-N-B	\$992.00	K-WP218-N-B	\$992.00
Blank Drawnut (7)	K-D210BLN-B	\$125.00	K-D212BLN-B	\$161.00	K-D215BLN-B	\$161.00	K-D218BLN-B	\$161.00
Master Jaws Set (3)	K-MJ210-N-B	\$1,172.00	K-MJ212-N-B	\$1,493.00	K-MJ215-N-B	\$1,601.00	K-MJ218-N-B	\$2,410.00
Plunger Nut (8)	K-PN210-N-B	\$326.00	K-PN212-N-B	\$262.00	K-PN215-N-B	\$375.00	K-PN218-N-B	\$375.00
Chip Cover (6)	K-CP210-N-B	\$175.00	K-CP212-N-B	\$175.00	K-CP215-N-B	\$375.00	K-CP218-N-B	\$375.00
Chuck Wrench (9)	K-CW210-N-B	\$212.00	K-CW212-N-B	\$191.00	K-CW215-N-B	\$196.00	K-CW218-N-B	\$221.00

**SAMCHULLY**  
MACHINERY CO. LTD.

REPLACEMENT PARTS FOR SAMCHULLY CHUCKS ALSO AVAILABLE-PLEASE CALL!

\*Kitagawa is a registered trademark of Kitagawa NorthTech. Samchully is a registered trademark of Samchully Workholding

## THREADED DRAWNUTS

Standard generic threaded drawnnuts are available for Strong N200, Samchully HS08 and Kitagawa® B200 Series Chucks. Please note- the thread on your drawnut may be different - **YOU MUST MEASURE THE THREADS ON YOUR MACHINES DRAWNUT BEFORE REPLACING.** Total Drawnut length is 1". Extended length standard threaded drawnnuts are available. Please call for Samchully® threaded and blank drawnnuts. Special threaded drawnnuts also available-please call for a quote.



Additional Thread Sizes Available-In Stock! Please Call for More Information

\*Kitagawa is a registered trademark of Kitagawa NorthTech. Samchully is a registered trademark of Samchully Workholding

Chuck Series	Threads on Drawnut	Part Number	Price Each
B205, N205	M40 x 1.5mm	K-D2054015N-B	\$268.00
B206 N206	M42 x 1.5mm	K-D2064215N-B	\$268.00
	M55 x 2.0mm	K-D2065520N-B	\$268.00
B208 N208	M50 x 2.0mm	K-D2085020N-B	\$268.00
	M55 x 2.0mm	K-D2085520N-B	\$268.00
	M60 x 2.0mm	K-D2086020N-B	\$268.00
B210, N210	M55 x 2.0mm	K-D2105520N-B	\$268.00
	M60 x 2.0mm	K-D2106020N-B	\$268.00
	M75 x 2.0mm	K-D2107520N-B	\$268.00
	M85 x 2.0mm	K-D2108520N-B	\$268.00
B212, N212	M75 x 2.0mm	K-D2127520N-B	\$268.00
	M85 x 2.0mm	K-D2128520N-B	\$268.00
	M88 x 2.0mm	K-D2128820N-B	\$268.00
	M100 x 2.0mm	K-D21210020N-B	\$268.00
B15, N215	M100 x 2.0mm	K-D21510020N-B	\$268.00
	M130 x 2.0mm	K-D21513020N-B	\$268.00
B18, N218	M130 x 2.0mm	K-D21813020N-B	\$268.00

Call Us Today For All Of Your Machine Tool Needs!

# HYDRAULIC CYLINDERS

TABLE OF CONTENTS

## ROTARY HYDRAULIC CYLINDERS

### Super High Speed Through Hole

Strong large thru-hole, high speed rotary hydraulic cylinders are for use with all thru-hole power chucks with speeds up to 7000RPM. All cylinders come with hydraulic pressure lock system and a built-in check valve.



**Strong**

F

LATHE CHUCKS  
LIVE CENTERS

WISE JAWS  
WISE ACCESSORIES

STRAIGHT SHANK  
COLLET HOLDERS

TAP HOLDERS  
DRILL CHUCKS

CARBIDE INSERTS  
THREADING/GROOVING

CUTTING TOOLS  
MACHINERY

PRECISION TOOLS  
DEBURRING

COOLANT/FLUIDS  
TOOL STORAGE

MODEL	Piston Dia	Piston Area		Piston Stroke	Draw Bar Pull Force		Max Op. Pressure	Max RPM	Moment Inertia	Weight	Total Leakage	Part Number	Price
		Push Side	Pull side		Push Side	Pull Side							
M1036	105	71	68.5	15	24.8(2529)	24(2447)	40.8	8000	0.011	8.6	3.0	K-CYM1036-B	\$1,969.00
M1236	125	100	89	15	38(3875)	33(3365)	40.8	7000	0.019	13.0	3.0	K-CYM1236-B	\$2,001.00
M1246	125	100	89	15	38(3875)	33(3365)	40.8	7000	0.019	12.0	3.0	K-CYM1246-B	\$2,001.00
M1546	155	161	150	22	60(6118)	56(5710)	40.8	6200	0.052	18.0	3.9	K-CYM1546-B	\$2,638.00
M1552	155	161	150	22	60(6118)	56(5710)	40.8	6200	0.052	16.8	3.9	K-CYM1552-B	\$2,638.00
M1868	180	198	183	25	75(7546)	69(7036)	40.8	4700	0.095	28.0	4.2	K-CYM1868-B	\$3,274.00
M1875	180	198	183	25	75(7546)	69(7036)	40.8	4700	0.095	26.0	4.2	K-CYM1875-B	\$3,274.00
M2091	205	252	234	30	94(9585)	94(9585)	40.8	3800	0.15	37.0	4.5	K-CYM2091-B	\$4,093.00
M2511	250	348	336	23	124(12644)	120(12236)	40.8	2800	0.45	57.0	7.0	K-CYM2511-B	\$6,548.00

## ROTARY HYDRAULIC CYLINDERS

### SYH Series-Standard Open-Center Cylinder

High Speed Open-centered Hydraulic Cylinders With Built In Lock And Relief Valves

**SAMCHULLY**

MACHINERY CO., LTD.

B

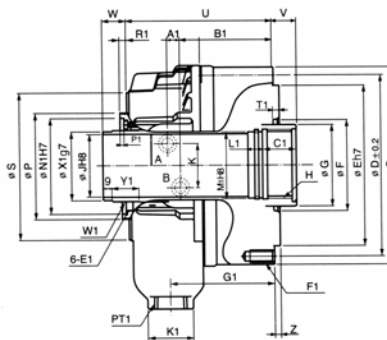
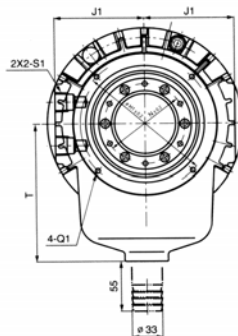
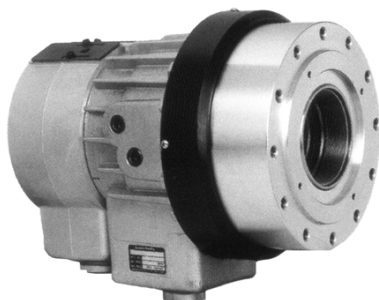

Available I.D.	Cylinder Dia (mm)	Piston Stroke (mm)	Piston Force		Max. Oper. Pressure	Max RPM	GD N·m²(kgf)	Weight (kgf)	Total Leakage	Industry Model #	Part Number	Price
			Push KN(kgf)	Pull KN(kgf)								
36	105	15	25(2549)	24(2447)	4.0(40.8)	8000	0.43(0.044)	8.6	3.0	S-1036	K-CYSYH-1036-H	\$2,500.00
36,39,40,40,43,45,46	125	15	38(3875)	33(3365)	4.0(40.8)	7000	0.76(0.078)	12.0	3.0	S-1246	K-CYSYH-1246-H	\$2,750.00
46,52,69	155	22	60(6118)	56(5710)	4.0(40.8)	6200	2.06(0.21)	16.8	3.9	S-1552	K-CYSYH-1552-H	\$2,900.00
68,69,75,77	180	25	74(7546)	69(7036)	4.0(40.8)	4700	3.73(0.83)	26.0	4.2	S-1875	K-CYSYH-1877-H	\$3,600.00
78,91	205	30	94(9585)	88(8973)	4.0(40.8)	3800	5.98(0.61)	33.0	4.5	S-2091	K-CYSYH-2091-H	\$4,500.00

#### Dimensions

Model	B1	C1	E1	F1	G1	H1	J1	K1	L1	M1	N1	P1	Q1	R1	S1	T1	U1	V1	G	X1
SYH-1036	102.5	25	M5x11	6-M10x17	98	88	73	47	15	38	64	4	M5x10	5	PT 3/8	6	158	28	48	42
SYH-1246	126.5	30	M6x9	12-M10x20	135	98	76	47	15	50	76	4	M5x10	6	PT 1/2	6	200	46	65	50
SYH-1552	136	30	M6x9	12-M10x20	145	110	86	47	15	55	85	4	M6x12	7	PT 1/2	6	220	51	70	56
SYH-1877	153.5	35	M6x9	12-M10x20	166.5	155	101	47	15	80	108	4	M6x12	7	PT 1/2	6	242	58	95	81
SYH-2091	168	35	M6x14	12-M12x24	183	165	110	47	15	95	120	4	M6x12	7	PT 1/2	6	267	66	110	96

C	D	E	Hmax.	W1	F	J	K	M	N	P	Q	S	T	U	Vmax.	Vmin	Wmax.	Wmin	Z	A1
135	115	100	M42x1.5	M44x1.5	65	36	30	44.6	55	73	45	104	115	156	15	0	40	25	5	11
155	130	100	M52x2.0	M52x1.5	80	46	36	52.9	64	85	51.5	118	115	184	15	0	40	25	5	11.5
190	170	130	M60x2.0	M58x1.5	85	52	36	59.6	73	96	57	137	130	191	22	0	47	25	5	12
215	190	160	M85x2.0	M84x2.0	120	75	36	84.6	98	121	70	166	160	230	25	0	50	25	5	17.5
240	215	180	M100x2.0	M99x2.0	140	91	34	99.6	108	138	79	182	185	253	30	0	55	25	5	21

Call Us Or Visit Our Website For Our Complete Selection!

2019-20 MASTER CATALOG

73