

# TAP WRENCHES/TAP ACCESSORIES

## T-HANDLE TAP WRENCHES

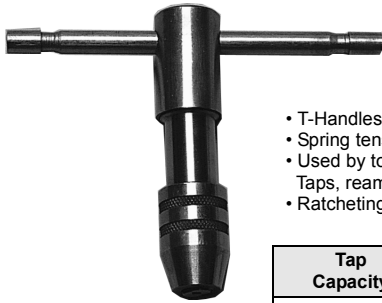

- T-Handles slide both ways for tightening
- Spring tension holds handle in desired position
- Used by toolmakers and mechanics for holding Taps, reamers and other small tools
- Ratcheting wrenches also available

Tap Capacity	Part Number	Price Each
1/16" to 5/32"	PEC-4300-210	\$6.99
5/32" to 1/4"	PEC-4300-220	\$7.59
1/4" to 1/2"	PEC-4300-230	\$7.99

## T-HANDLE TAP WRENCHES Ratcheting Type



- Ratcheting type
- Made of tool steel, hardened and ground
- Used for holding taps and reamers

TAP CAPACITY				
Size	Square Shank	Body Length	Part Number	Price Each
1/16-3/16"	1/16-5/32"	2-1/8	A-3900-0241	\$12.99
7/32-7/16"	5/32-1/4"	2-5/8	A-3900-0245	\$16.99
1/4-1/2"	1/4-1/2"	3-1/2	A-3900-0248	\$17.49

## PRECISION HAND TAPPER



- Precision ground work table and spindle for high accuracy
- 9 tap adapters included: #6, #8, #10, 1/4, 5/16, 3/8, 7/16, 1/2 & 5/8"
- Assures straight perpendicular tapped holes
- Rigid structure made of high grade tool steel
- Equipped with tap guide
- Working Area: 6-1/2" x 10"
- Clearance Height: 7"
- Depth of Throat: 7-1/2"
- Overall Height: 13"
- Weight: 37 lbs

**Hand Tapper**  
Part # A-3900-0250  
**\$175.00**

## ADJUSTABLE TAP & REAMER WRENCHES



- Knurled steel handles
- Hardened and tempered jaws
- Can be used for taps or reamers
- Buy the set and save over 10% than if purchased separately

**BUY THE SET & SAVE!**

Size	For Taps	OAL	Part Number	Price Each
#0	0-5/16"	5"	A-3900-0209	\$4.99
#1-1/2	1/32-1/2"	8"	A-3900-0210	\$5.99
#3	3/16-3/4"	15"	A-3900-0211	\$16.99
#4	7/16-1"	19"	A-3900-0235	\$25.50
4 Piece Set			A-3900-0236	\$48.00

## TAP WRENCH EXTENSIONS



- Precision tap extension
- Ideal for reaching taps into hard to reach areas

Tap Capacity	Shank	OAL	Part Number	Price Each
#0-12	3/8"	7"	A-3900-0218	\$10.99
#12-1/2"	1/2"	10-3/4"	A-3900-0219	\$12.99

## TAP GUIDE



**Spring-Loaded!**

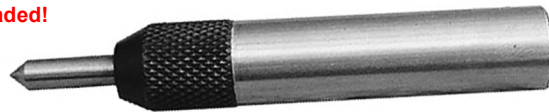

- Adjustable tension spring
- Reversible tension pin for male and female hole centering or tapping
- 1/2" diameter hardened shank knurled for easy handling
- 3/16" diameter hardened tension pin

**For Drill Presses & Mills**

**Tap Guide**  
Part # A-3900-0215  
**\$6.99**

## ELECTRIC HAND TAP



Palmgren's portable electric hand tapper makes it convenient, efficient and easy to tap a series of holes quickly. For general purpose tapping, making time consuming hand tapping obsolete. Push down on the spindle to get clockwise rotation with a spindle rpm of 280 revolutions per minute. At the desired depth you pull up on the spindle for a counter clockwise rotation and the tap exits the threaded hole at 680 revolutions per minute. The high reversal motor is wound for high torque and low rpm making it ideal for tapping applications.



- Ergonomic comfort handle
- Depth stop for blind hole tapping
- Universal 2 jaw tapping chuck
- Adjustable long side handle can be mounted and used from either right or left side
- Power input: 4A
- Includes molded plastic case

Tapping Capacity					
Steel	Aluminum	Voltage	Dimensions	Part Number	Price Each
9/16"	5/8"	115v-60Hz	15.75" x 3.15" x 7.87"	PALM-80452	\$510.00

**Call Us Today For All Of Your Machine Tool Needs!**